

TORQ-ARM™ for ASSEMBLY TOOLS

COMPLETE WORKSTATION KIT OR TORQ-ARM ONLY

ACCESSORIES



Workplace Solutions

Take a step towards OSHA Ergonomics standard compliance by fitting workstations with **Torq-Arm™** Torque Neutralizing arms. Available for either air or electric tools. Light weight anodized aluminum arms support weight of tool and allow easy positioning while preventing transmission of rotational forces to worker's hands or wrists. Units include tool balancer, telescoping positioning arms and rolling trolley for mounting in lateral tool rail on workstation or on bench mounted jib with swing boom (jib included). Electric tool models feature secure tool clamp which may also be used for electric or air powered pistol grip tool. Air tool models feature a U-joint manifold which supplies air to tool and allows vertical and horizontal tool positioning. **JIB MOUNTED TORQ-ARM™ KIT** includes all parts necessary for assembling a complete, ergonomically correct TORQ-ARM™ on an existing bench. Maximum torque rating is 15 foot pounds (20N.m). All steel parts protected with durable baked polyester finish. Order model for correct type and weight tool. Tools not included.



BOOM MOUNTED TORQ-ARM™ (boom not included)

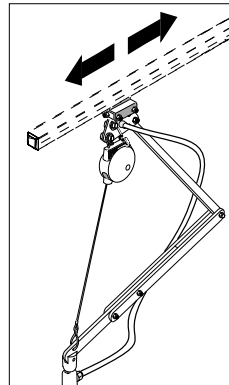

JIB MOUNTED TORQ-ARM™ (includes jib)

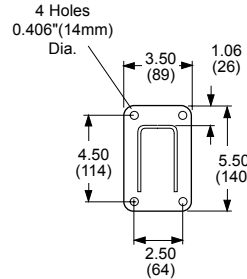

WS50-TB MOUNTING BASE DIMENSIONS

#WS50-TBS Backing Plate Optional. Recommended on wood or composite tops.

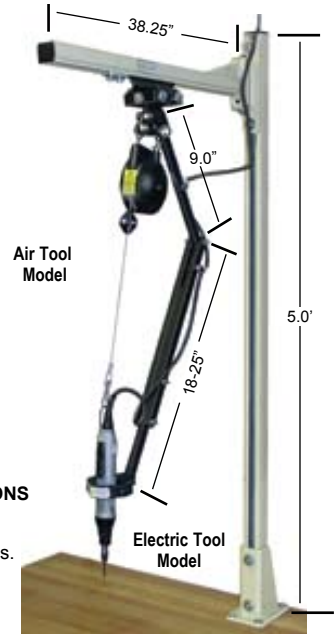

BOOM MOUNTED TORQ-ARM™ includes 9"(229mm) fixed arm, 18"-25"(457-635mm) telescoping arm, tool balancer, mounting trolley, and all related hardware. Air tool models include U-joint manifold and air line with fittings. Electric tool models include tool clamp. **Boom not included.** See chart below.

BENCH MOUNTED TORQ-ARM™ JIB includes (1) WS30 swing boom, (1) WS50 vertical column with base, (2) end caps, (1) end stop, hardware for mounting boom to column and column to base, and (1) TORQ-ARM™ kit including 9"(229mm) fixed arm, 18"-25"(457-635mm) telescoping arm, tool balancer, mounting trolley, and all related hardware. Air tool models include U-joint manifold and air line with fittings. Electric tool models include tool clamp.

TORQ-ARM™ ONLY-BOOM MOUNTED

Min. - Max. TOOL WEIGHT	TOOL TYPE	UNIT WEIGHT	MODEL NUMBER	
			WS30 BOOM	WS50 BOOM
0.5-1.5 lbs. (0.2-0.7 kg)	Air	5 lbs. (2.25 kg)	WS30-FA-1	WS50-FA-1
1.5-3.0 lbs. (0.7-1.4 kg)	Air	5 lbs. (2.25 kg)	WS30-FA-2	WS50-FA-2
3.0-5.0 lbs. (1.4-2.3 kg)	Air	5 lbs. (2.25 kg)	WS30-FA-5	WS50-FA-5
0.5-1.5 lbs. (0.2-0.7 kg)	Electric	5 lbs. (2.25 kg)	WS30-FE-1	WS50-FE-1
1.5-3.0 lbs. (0.7-1.4 kg)	Electric	5 lbs. (2.25 kg)	WS30-FE-2	WS50-FE-2
3.0-5.0 lbs. (1.4-2.3 kg)	Electric	5 lbs. (2.25 kg)	WS30-FE-5	WS50-FE-5

TORQ-ARM™ mounted on Jib with Swing Boom. Mounts to bench top. Jib included.

Min. - Max. TOOL WEIGHT	TOOL TYPE	UNIT WEIGHT	MODEL NUMBER
0.5-1.5 lbs. (0.2-0.7 kg)	Air	20 lbs. (9 kg)	WS30-RA-1
1.0-2.50 lbs. (0.5-1.1 kg)	Air	20 lbs. (9 kg)	WS30-RA-2
2.0-5.0 lbs. (0.9-2.3 kg)	Air	20 lbs. (9 kg)	WS30-RA-5
0.5-1.5 lbs. (0.2-0.7 kg)	Electric	20 lbs. (9 kg)	WS30-RE-1
1.0-2.50 lbs. (0.5-1.1 kg)	Electric	20 lbs. (9 kg)	WS30-RE-2
2.0-5.0 lbs. (0.9-2.3 kg)	Electric	20 lbs. (9 kg)	WS30-RE-5

RAIL MOUNTED TORQ-ARM™

Rail Not Included

Designed to be mounted on straight overhead tool rails. Specify **WS30** or **WS50** rail. See chart below. For optional swing lock, order #625288.

OVERHEAD RAIL MOUNTED TORQ-ARM™ includes 9" (229mm) fixed arm, 18"-25" (457-635mm) telescoping arm, tool balancer, mounting trolley for WS30 or WS50 straight rail (check rail size before ordering), and all related hardware. Air tool models include U-joint manifold and air line with fittings. Electric tool models include tool clamp. Mounting rail and tool not included.

TORQ-ARM™ ONLY-RAIL MOUNTED

Min. - Max. TOOL WEIGHT	TOOL TYPE	UNIT WEIGHT	MODEL NUMBER	
			WS30 RAIL	WS50 RAIL
0.5-1.5 lbs. (0.2-0.7 kg)	Air	5 lbs. (2.25 kg)	WS30-TA-1	WS50-TA-1
1.5-3.0 lbs. (0.7-1.4 kg)	Air	5 lbs. (2.25 kg)	WS30-TA-2	WS50-TA-2
3.0-5.0 lbs. (1.4-2.3 kg)	Air	5 lbs. (2.25 kg)	WS30-TA-5	WS50-TA-5
0.5-1.5 lbs. (0.2-0.7 kg)	Electric	5 lbs. (2.25 kg)	WS30-TE-1	WS50-TE-1
1.5-3.0 lbs. (0.7-1.4 kg)	Electric	5 lbs. (2.25 kg)	WS30-TE-2	WS50-TE-2
3.0-5.0 lbs. (1.4-2.3 kg)	Electric	5 lbs. (2.25 kg)	WS30-TE-5	WS50-TE-5

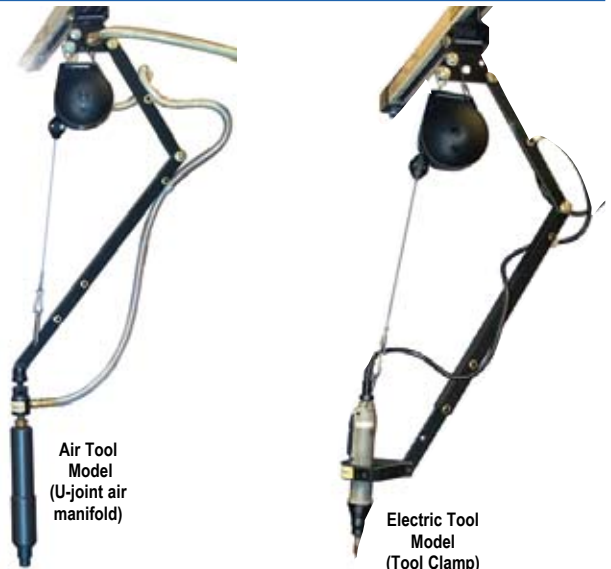



Workplace Solutions

TOOL POSITIONERS

NEUTRALIZE TORQUE...ELIMINATE TOOL LIFTING

Tool Positioners stop shock and torque transmission to wrists and arms, one of the major causes of musculoskeletal disorders (MSDs). Dual parallel arms also keep tool in a vertical position as it is moved across work area, eliminating need to lift or twist tool. Spring tension is adjustable for tools from 1.0–7.0 pounds. Air tools (AM models) attach directly to bottom of air manifold. Electric tools (EC models) clamp to adapter plate. **Choice of positioner mounting.** Post models mount to top of work surface...positioner is adjustable on 26" post (included). Column mounted positioners include adjustable bracket for attaching to workstation upright. Maximum torque rating is 97 inch pounds (11N.m).

- Reduces transmission of shock and torque to worker's hand, wrist or arm
- Automatically positions tool perpendicular to work piece
- Adjustable tension supports air or electric powered tools from 1.0–7.0 lbs.
- **Arm reach: 15" minimum – 31.5" maximum from base pivot point**

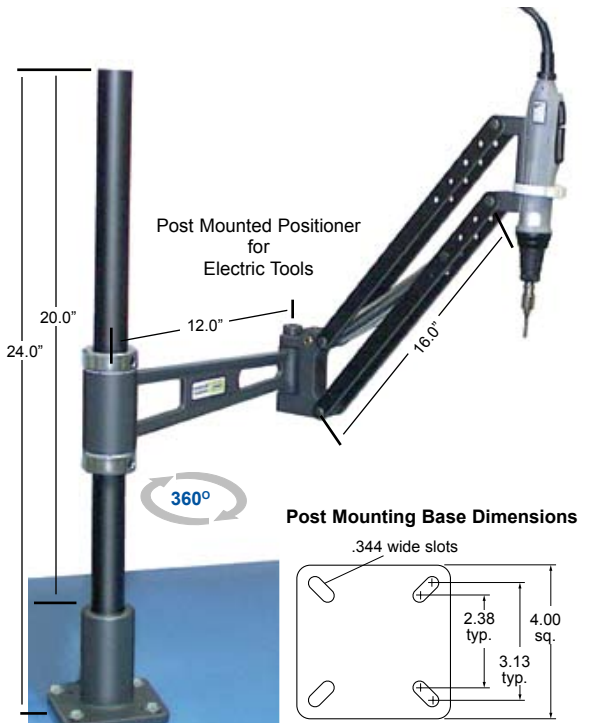

Min. - Max. TOOL WEIGHT	TOOL TYPE	MOUNTING TYPE	UNIT WEIGHT	MODEL NUMBER
1.0 – 7.0 lbs. (0.45–3.15 kg)	Air	Post (post included)	5 lbs. (2.25 kg)	WSP-AM
1.0 – 7.0 lbs. (0.45–3.15 kg)	Air	Bracket (bracket included)	5 lbs. (2.25 kg)	WS50-AM
1.0 – 7.0 lbs. (0.45–3.15 kg)	Electric	Post (post included)	5 lbs. (2.25 kg)	WSP-EC
1.0 – 7.0 lbs. (0.45–3.15 kg)	Electric	Bracket (bracket included)	5 lbs. (2.25 kg)	WS50-EC