

# GLEASON® PowerTrak® CABLE/HOSE CLAMPS

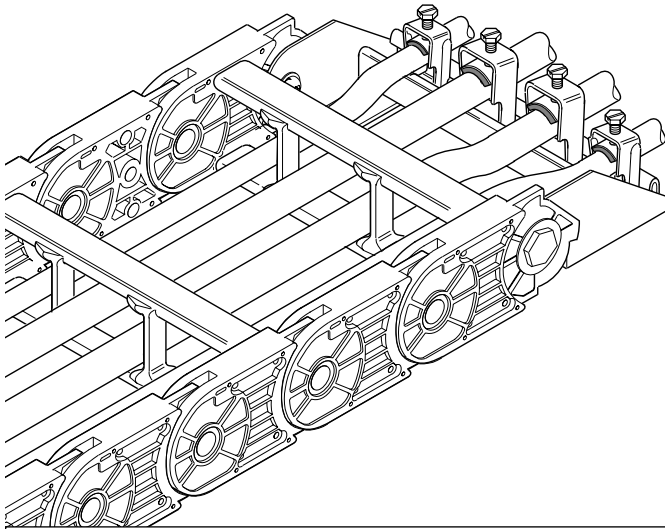

- Affixes hoses or cables at ends of trak to prevent undue wear or stress.
- Six sizes, for hose or cable 0.38" to 2.18" O.D.
- Rugged zinc plated steel for long life.
- Heavy duty galvanized steel mounting bracket.
- All clamps fit one mounting bracket. To install cable, simply twist proper size clamp into mounting bracket and securely tighten clamping bolt.

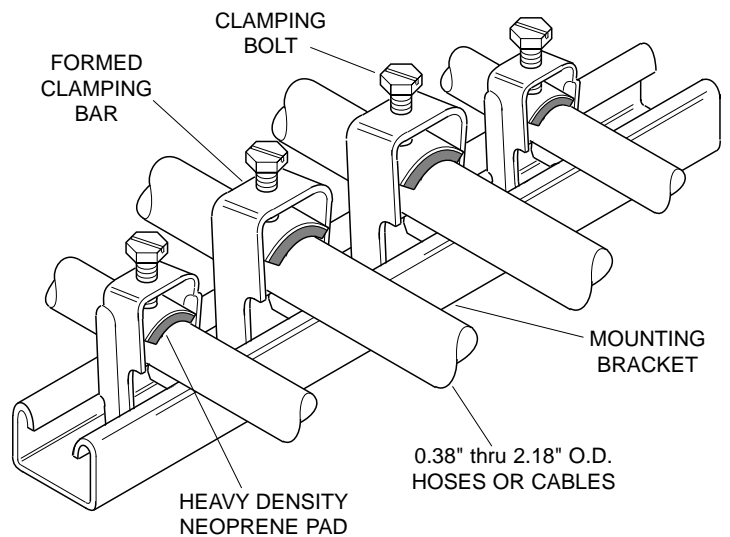
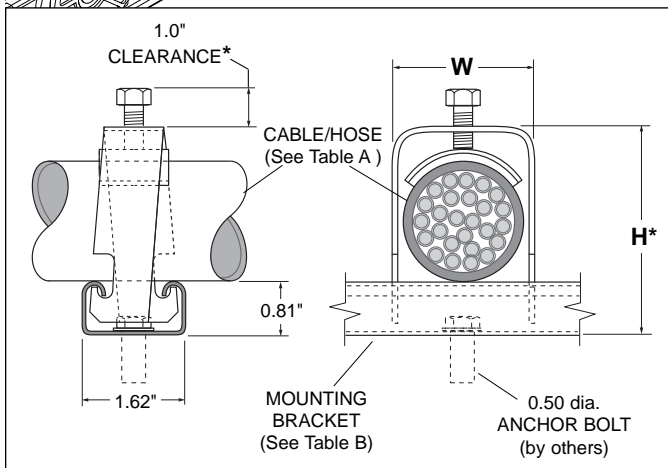

**MOUNTING BRACKET  
MODEL CHART-TABLE B**

\* Check for clearance at *fixed* end on long trak runs in guide tray.  
**Dimension H + 1.0" must not exceed height of trak link.** Use bar clamp in this application. Consult factory for details.

**CLIP MODEL CHART-TABLE A**

CABLE / HOSE O.D. (inches)	WIDTH W (inches)	HEIGHT H (inches)	CLIP PART NUMBER
0.38 thru 0.62	1.1	2.1	04095101
0.63 thru 0.88	1.4	2.4	04095102
0.89 thru 1.12	1.6	2.5	04095103
1.13 thru 1.38	2.1	2.8	04095104
1.39 thru 1.75	2.3	3.0	04095105
1.76 thru 2.18	2.7	3.5	04095106

CARRIER WIDTH** (inches)	MOUNTING BRACKET PART NO.
4.00	03946501
6.00	03946502
8.00	03946503
10.00	03946504
12.00	03946505
14.00	03946506
16.00	03946507
18.00	03946508

\*\* Mounting bracket length is 0.25" greater than carrier width.



## Gleason Reel Corp.

P.O. Box 26, 600 S. Clark St.  
 Mayville, Wisconsin 53050-0026  
 Phone 920-387-4120 • FAX 920-387-4189