

GLEASON **PowerTrak[®] GRP**

Non-Metallic Cable/Hose Carrier

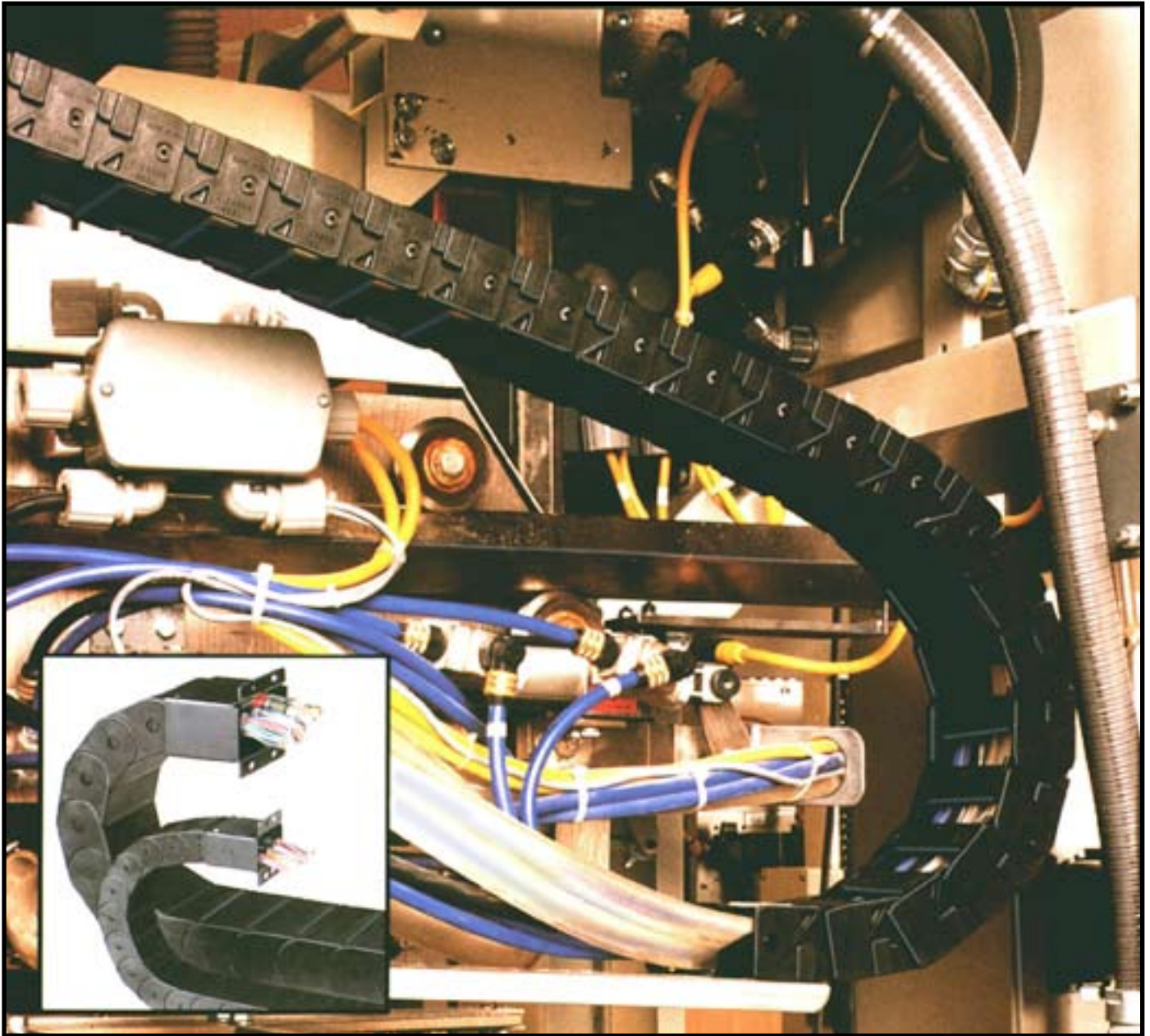

Contains POWERTRAK[®] GRP and POWERTUBE[™]



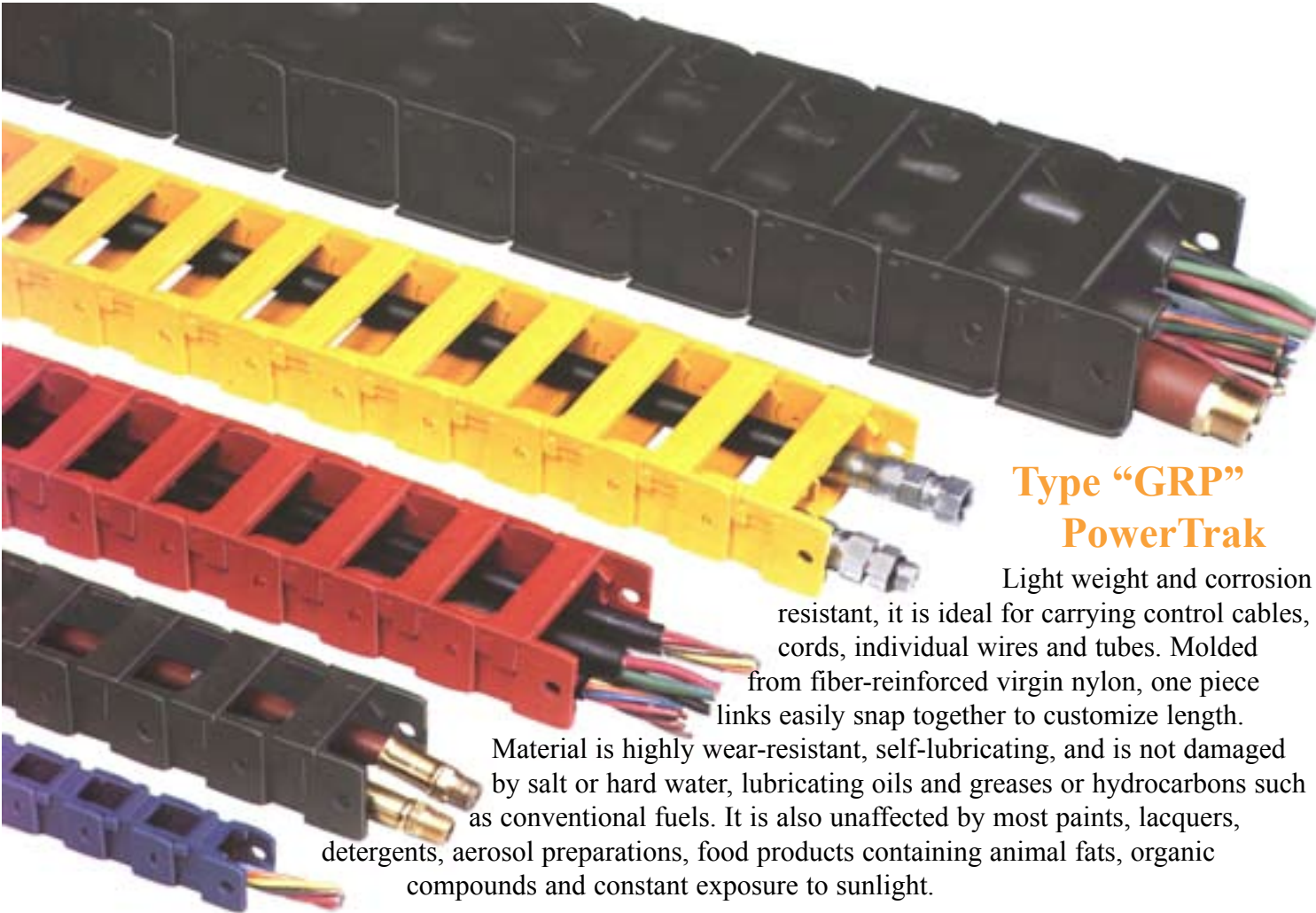

Type “GRP” PowerTrak

Light weight and corrosion resistant, it is ideal for carrying control cables, cords, individual wires and tubes. Molded from fiber-reinforced virgin nylon, one piece links easily snap together to customize length.

Material is highly wear-resistant, self-lubricating, and is not damaged by salt or hard water, lubricating oils and greases or hydrocarbons such as conventional fuels. It is also unaffected by most paints, lacquers, detergents, aerosol preparations, food products containing animal fats, organic compounds and constant exposure to sunlight.

Type “GRP” PowerTrak is available with inside openings from 0.75" x 0.59" to 2.55" x 8.00" for cables or hoses with a maximum outside diameter of 2.12". Maximum total travel is 300 feet when optional guide tray is used. Most sizes have flip open tops for easy access to cables, cords and hoses. Guide tray not suitable for use with all models.

PowerTrak is available in a variety of styles and materials. Metallic or non-metallic, Gleason offers a carrier trak to fit every application.

- **Five types**
- **Many carrier styles**
- **Hundreds of sizes**
- **Custom lengths**

Protect cables and hoses on reciprocating machinery. Increase safety by keeping cables and hoses together, away from moving components and operations.

PowerTrak is available in a variety of styles and materials, including flip-open for easy access to cables and hoses. Metallic or non-metallic, Gleason offers a carrier trak to fit every application.

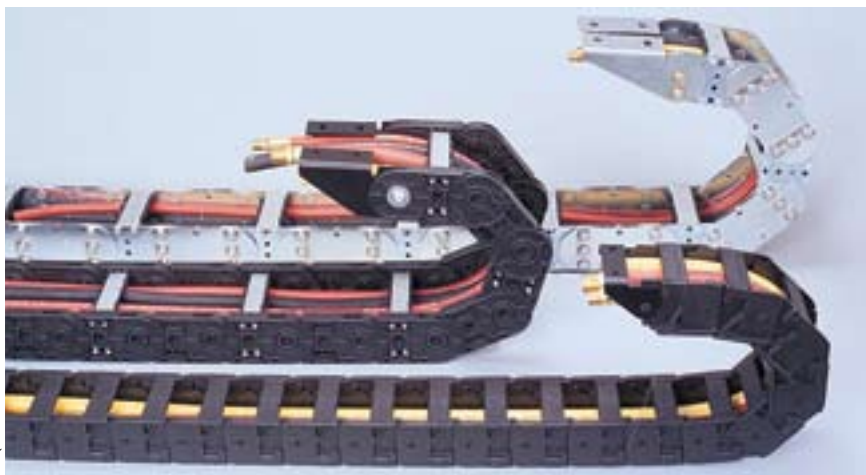

Available in this catalog...

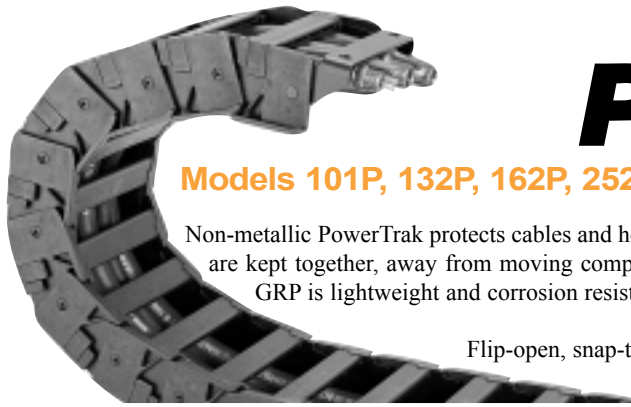

GLEASON **PowerTrak** GRP

Models 101P, 132P, 162P, 252P, 263P, 354P

Non-metallic PowerTrak protects cables and hoses on reciprocating machinery. Safety is increased when cables and hoses are kept together, away from moving components and operators. Capable of X and Y and Z axis motion, PowerTrak GRP is lightweight and corrosion resistant.

Flip-open, snap-together links provide on-site flexibility and easy access to cables and hoses (not available on types 101P and 132P).

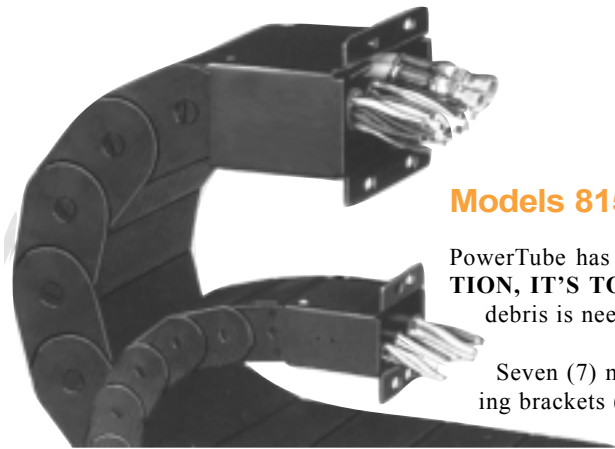

GLEASON **PowerTube**

Models 815, 1020, 1530, 2045

PowerTube has the same non-metallic advantages as PowerTrak GRP **BUT IN ADDITION, IT'S TOTALLY ENCLOSED!** When protection from HOT CHIPS and other debris is needed, PowerTube offers a low cost solution with high aesthetic value.

Seven (7) models to choose from with flange-type (pictured) or scoop-type mounting brackets (standard).

Contents

General Information	PAGE
Open or Enclosed?.....	3
PowerTrak GRP Features	5
Applying PowerTrak	6-7
Cable/hose Ties.....	23
Selection	PAGE
QUICK-REFERENCE Selection Guide	8
Three Steps for Selecting & Ordering	9-11
Technical Data	PAGE
PowerTrak GRP Data by Type	
Type 101P & 101PS.....	12-13
Type 132P	14
Type 162P	15
Type 252P	16
Type 263P	17
Type 354P	18
PowerTube Data by Type	
Type 815.....	20
Type 1020.....	21
Type 1530.....	22
Type 2045.....	23
Tray Systems.....	24-25
Cable & Hose Data.....	26

GLEASON **PowerTrak** GRP



Made in USA



Type GRP PowerTrak protects power cable and allows unhindered movement on case erecting machine.

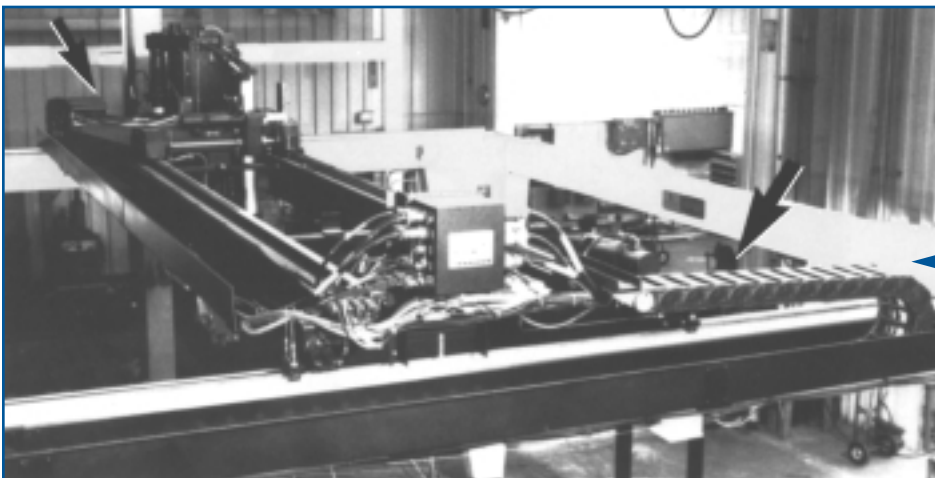
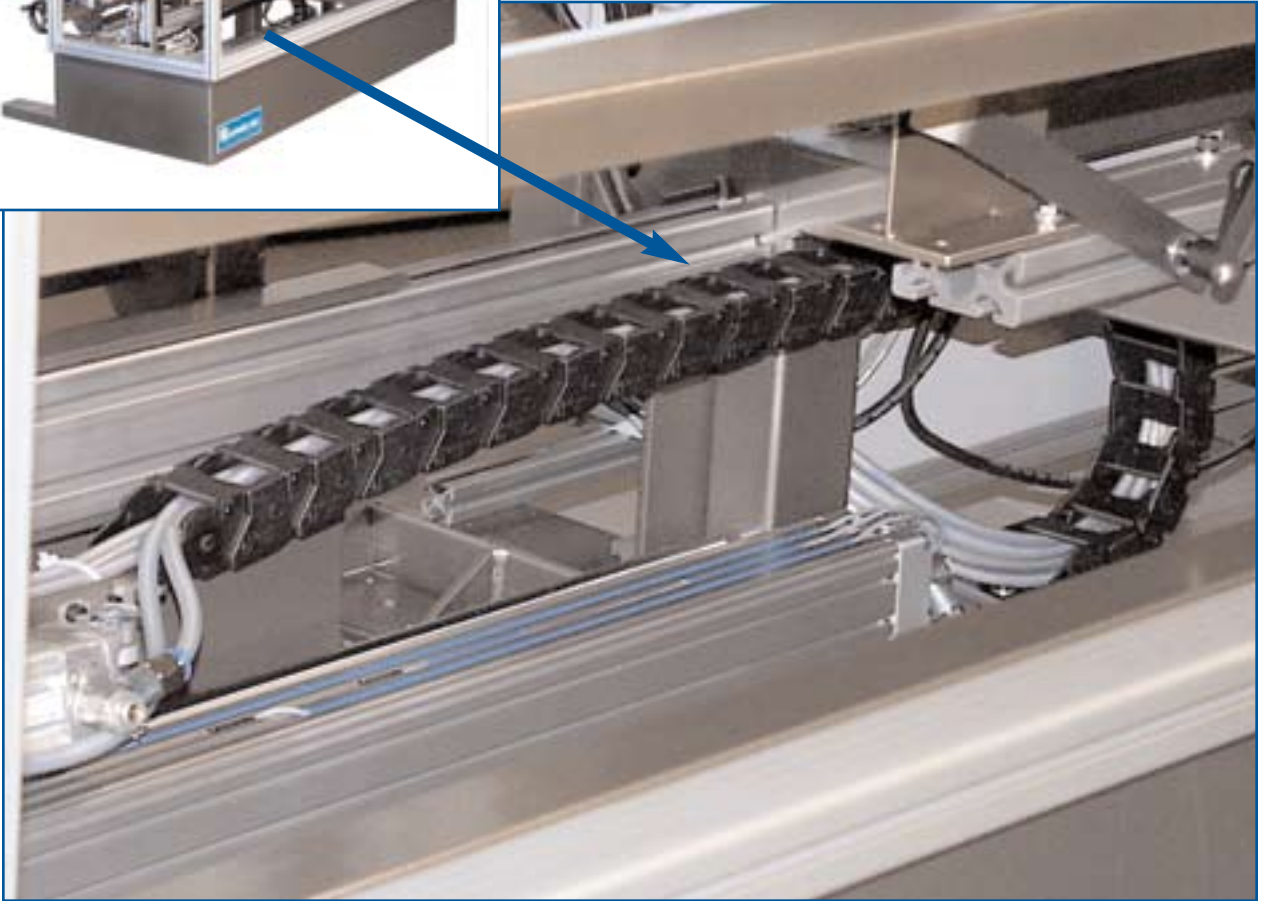

Two PowerTrak 354P PowerTrak systems installed in Guide Trays for extended travel.

**QUICK, Easy-loading Flip-Tops
Pivot and Lock from Either Side**

Unlock Tab...

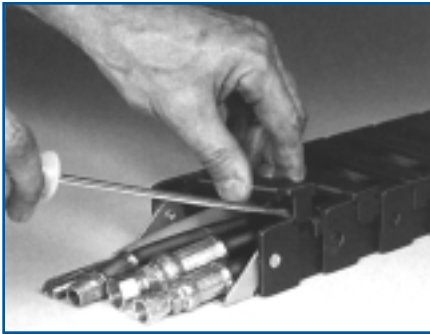

Locking tab securely holds Flip-Top in position but unlocks easily with a screwdriver using a twisting motion.

Access Cables/Hoses...

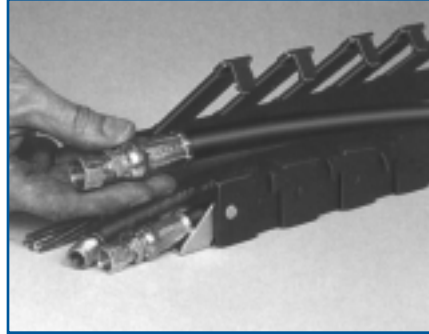

Easy access is important, especially for pre-assembled cable/hose sets involving large O.D. plugs, receptacles and couplings.

Lock Tab.

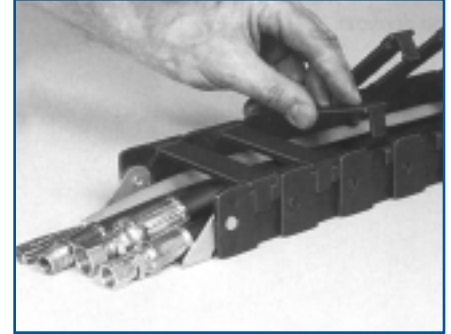

To lock the Flip-Tops, engage the pivot and push the locking tab securely into place.

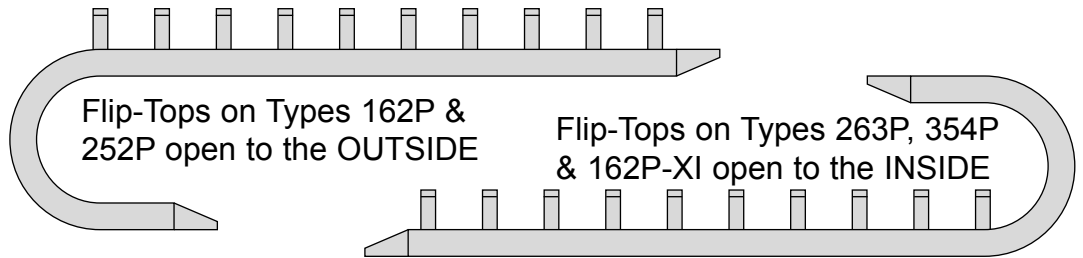

Type 101P Features Unique "SNAP-OUT" Carrier Bar

Speeds cable/hose installation. No tools required to snap bars in to hold cables/hoses firmly in place. Bars snap out easily with a pliers.



Cable/Hose Carrier Options

Cable/Hose Separators available for most models
(Two STANDARD on Types 263P & 354P)

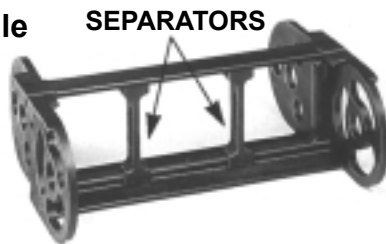

Machined Nylon Bar Carriers available for Types 263P & 354P

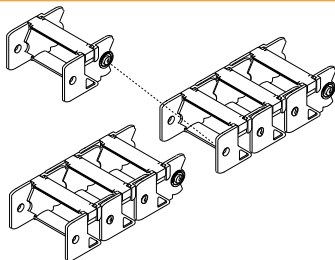

Add or Remove Links to Change Length – No Special Tools Required

Molded nylon links easily snap together to customize PowerTrak system length.

**Lightweight
Non-Conductive
Resists Corrosion**

MATERIAL: PowerTrak GRP is made from fiber-reinforced virgin nylon. Highly wear resistant, this material is self-lubricating and is not damaged by salt and hard water, lubricating oils and greases or hydrocarbons such as conventional fuels. The material is unaffected by most paints, lacquers, detergents, aerosol preparations, food products containing animal or vegetable fats, organic compounds and constant exposure to sunlight. If ambient conditions are extreme, please consult the factory for recommendations.

Applying **GLEASON PowerTrak[®] GRP**

PowerTrak is most often used in the horizontal Standard Travel configurations, described on this page. TWO-WAY PAYOUT is normally used with Standard Travel.



Two-way payout means locating the cable/hose source at the CENTER of machine travel so that cables/hoses are used in TWO directions. Thus, using two-way payout, the PowerTrak you order will be just one-half of the Total Travel distance that you require, plus a little more to form the curve, as illustrated below.

STANDARD TRAVEL

- Two-way payout (center-fed)
- Upper section is self-supported, roller supported or, for extended travel, may ride on itself or on a carriage
- Lower section is supported by a surface

Variations

Opposed Travel is the most common variation to Standard Travel. Two smaller PowerTraks in the Opposed configuration can do the same work as a larger size using Standard Travel. Opposed Travel is a valid option when there are width restrictions or when cables and hoses must be separated.



Opposed Travel involves TWO PowerTraks opposed to one another, each operating in the Standard Travel configuration. Cables/hoses are distributed between the two PowerTraks increasing operating life. Length of each trak is same as one standard travel trak in given application, but type and width of trak may be smaller.

OPPOSED TRAVEL

- TWO PowerTraks, two-way payout on each
- Upper sections self-supported or may ride on lower section or carriage
- Lower sections are supported by a surface
- Roller supports are not available
- ⇨ Overall width may be reduced
- ⇨ Cables and hoses may be separated

CURVE AT TOP

Vertical Travel

Vertical Travel in the Curve at Top or Curve at Bottom configuration is possible when PowerTrak is properly supported:

- A back-up SURFACE ① is preferred for one side of the PowerTrak.
- A back-up PLATE ② must extend a minimum of four (4) links.

- Typically two-way payout (center-fed)
- Back-up surface ① and back-up plate ② used to support PowerTrak
- ⇨ Curve at Bottom provides greater Total Travel capabilities than Curve at Top.

CURVE AT BOTTOM

Lift

Lifting is possible when PowerTrak is properly supported:

- Vertical retaining walls \neq extending the full height of PowerTrak in the stored position are required.
- ONE-WAY payout
- Lower section is fully supported
- END-FED (“Bottom Fed”) in relation to machine travel
- Vertical retaining walls ③ required
- Upper section is SELF-SUPPORTING
- Special reverse bend links are required

Other Variations

One-Way Travel

Applied where situation prohibits center-feeding of cables/hoses. Roller supports may be added to increase Total Travel capabilities.

- ONE-WAY payout (end-fed in relation to machine travel)
- Upper section is SELF-SUPPORTING
- Lower section is supported by a surface
- Roller supports may be added — consult factory

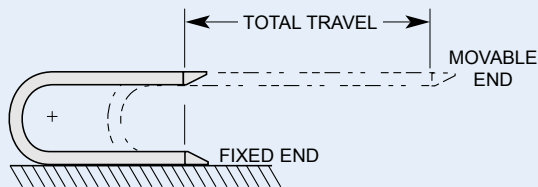

Nested Travel

Two PowerTraks having different bend radii allowing one to nest within the other. Cables/hoses are distributed between the two PowerTraks increasing operating life.

- TWO PowerTraks, two-way payout on each
- Upper sections must be SELF-SUPPORTING
- Lower sections are supported by a guide tray
- Both PowerTraks must be same width
- Roller supports are not available
- ➔ Overall width may be reduced
- ➔ Cables and hoses may be separated

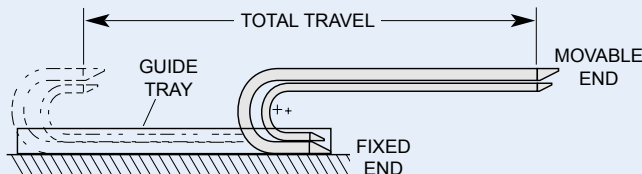

Combination Travel

PowerTrak can travel the full vertical and horizontal range of motion illustrated.

- Vertical & horizontal payout
- Typically CENTER-FED
- Upper section is SELF-SUPPORTING
- Lower section is fully supported

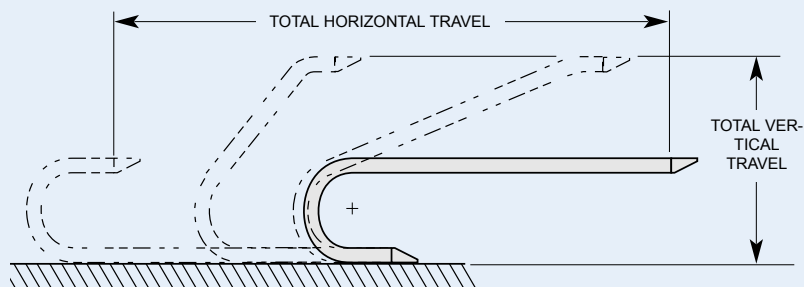

Traveling on Edge

PowerTrak will travel on its edge with the addition of a guide tray. Edge-travel distributes cable/hose weight over a greater support area for improved life expectancy and is typically chosen when height restrictions apply.

- Two-way payout (center-fed)
- PowerTrak is fully supported by guide tray
- ➔ Overall height may be reduced
- ➔ Improved life expectancy for PowerTrak

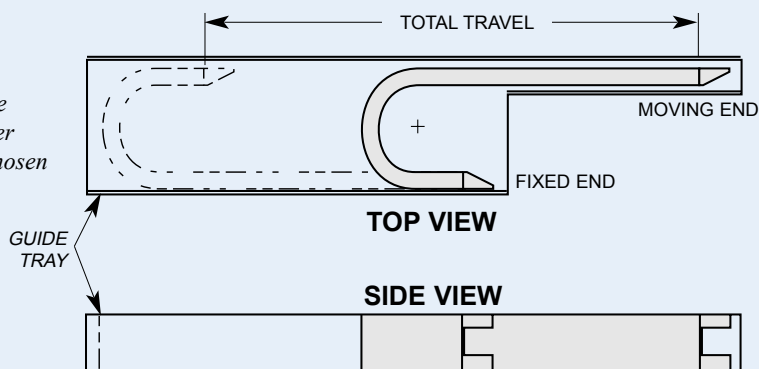

Cantilevered Travel

PowerTrak GRP may be cantilevered as illustrated for short travel distances. Total Travel of PowerTrak CANNOT exceed 35% of the "Self Supported No Sag Total Travel" shown for each model.

- Typically two-way payout.
- Typically center-fed.
- Upper section is SELF-SUPPORTING.
- Lower section is SELF SUPPORTING.

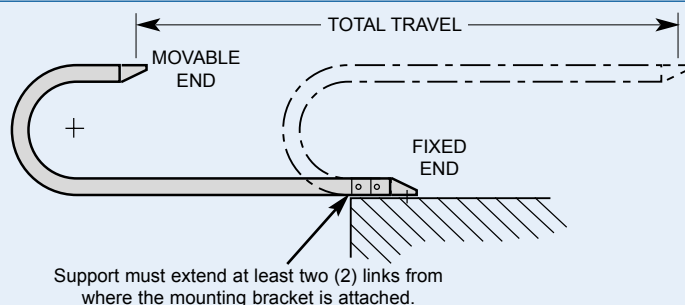

QUICK REFERENCE Selection Guide

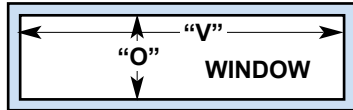

OPEN SOLID LINK DESIGN	OPEN SWAP-OUT CARRIER BARS	OPEN FLIP-TOP DESIGN	ENCLOSED DESIGN	SEPARATORS INCLUDED (2)	SEPARATORS AVAILABLE	MACHINED BAR CARRIER AVAIL.	RIVETED CONSTRUCTION AVAIL.	GUIDE TRAY AVAILABLE
------------------------	----------------------------	----------------------	-----------------	-------------------------	----------------------	-----------------------------	-----------------------------	----------------------

PowerTrak Type	Cable/Hose Max. O.D. Allowed	Window Width V	Window Height O	Bend Radius A	Length to Form Curve L(ft.)										
101P-I	0.34	0.59	0.75	1.43	1.0	●									
101P-II	0.62	1.00	0.75	1.43, 1.91	1.0, 1.0	●									
101P-IS	0.34	0.59	0.75	1.43	1.0		●								
101P-IIS	0.62	1.00	0.75	1.43, 1.91	1.0, 1.0		●								
132P-I	0.82	1.50	0.98	2.05, 3.70	1.0, 1.5	●					●		●	●	
132P-II	0.82	2.28	0.98	2.05, 3.70	1.0, 1.5	●					●		●	●	
132P-III	0.82	3.08	0.98	2.05, 3.70	1.0, 1.5	●					●		●	●	
162P-I	0.83	1.50	1.00	1.91, 3.44	1.0, 1.5			●			●		●	●	
162P-XI	0.83	1.50	1.00	3.44	1.5			●			●		●	●	
162P-II	0.83	2.28	1.00	1.91, 3.44	1.0, 1.5			●			●		●	●	
162P-III	0.83	3.08	1.00	1.91, 3.44	1.0, 1.5			●			●		●	●	
162P-IV	0.83	4.06	1.00	1.91, 3.44, 7.87	1.0, 1.5, 2.5			●			●		●	●	
252P-I	1.46	2.60	1.75	3.40, 4.78, 7.73	1.5, 2.0, 2.5			●			●		●	●	
252P-II	1.46	4.25	1.75	3.40, 4.78, 7.73, 10.73, 11.67	1.5, 2.0, 2.5, 3.0, 3.5			●			●		●	●	
252P-IIA	1.46	4.25	1.75	2.75	1.5	●					●		●	●	
252P-III	1.46	6.60	1.75	4.78, 7.73	2.0, 2.5			●			●		●	●	
263P*	1.46	6.00	1.75	3.67, 7.42, 10.92	1.5, 2.5, 3.5			●			●	●	●		●
354P*	2.13	8.00	2.55	6.91, 11.25	2.5, 3.5			●			●	●	●		●
PowerTube Type	Cable/Hose Max. O.D. Allowed	Window Width V	Window Height O	Bend Radius A	Length to Form Curve L(ft.)										
815	0.68	1.50	0.81	2.34	1.0					●					●
1020	0.83	2.00	1.0	3.25, 5.88	1.5, 2.0					●					●
1530	1.25	3.00	1.50	4.12, 7.75	2.0, 3.0					●					●
2045	1.67	4.50	2.00	5.88, 8.38	2.5, 3.5					●					●

* When machined nylon bar carrier option is used, max. O.D. for use with Type 263P is 1.13", max. O.D. for Type 354P is 1.69".

Ordering PowerTrak GRP

Step 1

DEFINING YOUR CABLE/HOSE "PACKAGE"

Picture your cables and hoses as a GROUP, what we call a cable/hose "PACKAGE."

- Package must fit into a PowerTrak WINDOW. Allow for at least 20% clearance. See Fig. 1 and refer to [Selection Guide](#).
- PowerTrak should NOT have a radius less than the minimum bending radius of the least flexible cable or hose in your package, usually the recommended minimum bend radius of the largest cable or hose in your package (Fig 2).

IMPORTANT: Information about your cables and hoses is CRITICAL for selecting the correct PowerTrak.

FIG. 1 PowerTrak Cross Section

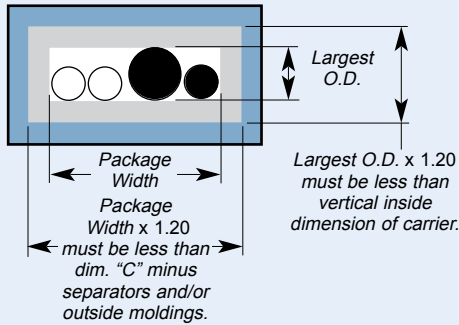

Your package must fit a window.

FIG. 2 Cable/Hose Bend Radius

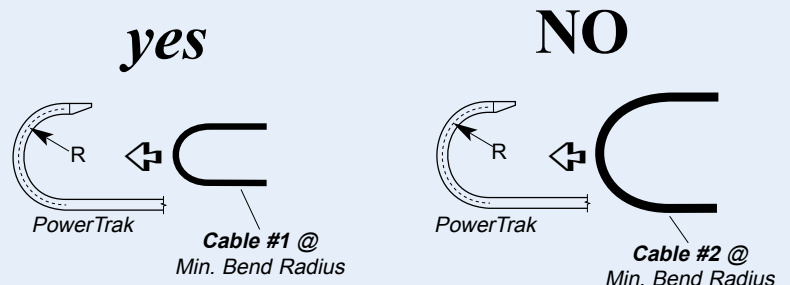

PowerTrak must have a large enough radius.

Fill in all of the blanks in the Worksheet below (if necessary, refer to "Cable & Hose Data" in this catalog for diameters and weights of typical cables and hoses).

Cable/Hose Descrip. (Include Qty of each @ right)	J O.D.	D Min. Bend*	A Lbs/Ft	Q Quantity	AQ (A x Q)	JQ (J x Q)
_____	_____	_____	_____	_____	_____	_____
_____	_____	_____	_____	_____	_____	_____
_____	_____	_____	_____	_____	_____	_____
_____	_____	_____	_____	_____	_____	_____
_____	_____	_____	_____	_____	_____	_____
_____	_____	_____	_____	_____	_____	_____
_____	_____	_____	_____	_____	_____	_____
_____	_____	_____	_____	_____	_____	_____
_____	_____	_____	_____	_____	_____	_____

TOTAL NO. OF CABLES/HOSES (for machined bar carrier option) → $Q_{SUM} =$ _____

TOTAL CABLE/ HOSE WEIGHT → $AQ_{SUM} =$ _____ Lbs/ft

PKG WIDTH (Total of all O.D.s) → $JQ_{SUM} =$ _____ In

PKG HEIGHT (Largest O.D. [J] of all) _____ Inches

PKG MINIMUM BEND RADIUS* _____ Inches

*PKG MINIMUM BEND RADIUS: Your package should only bend as tight as the LARGEST recommended min. bend radius of all cables or hoses in your package. Generally, but not always, the minimum bend radius is largest on your LARGEST O.D. cable/hose. Bend radius information should be available from the cable/hose manufacturer. If no information is available, a good method for determining min. bend radius of your package is to multiply your LARGEST O.D. by a factor of 6 (six): [6 x O.D.].

Step 2

SELECT POWERTRAK GRP TYPE AND RADIUS

Select a **PowerTrak GRP or PowerTube type** with a window size large enough to hold your cable/hose package (Step 1). The **Selection Guide** shows the largest diameter cable that can be used in each type PowerTrak. In addition, the cable/hose package width X 1.20 must be equal to or less than Dimension "V" (**Selection Guide**).

Select a **PowerTrak GRP or PowerTube Radius** (dimension "A" from **Selection Guide**) LARGER than the Minimum Bending Radius of the stiffest cable or hose in your package (Step 1).

Construct a Model Number:

Typical
Model No.

162P-II - 1.9

FIRST...Enter "TYPE" chosen **162P-II**

SECOND...Enter BEND "RADIUS" 162P-II - **1.9**

To complete order...Supply LENGTH. See **Step 3, DETERMINING LENGTH**.

Additional Considerations for Applying PowerTrak GRP or PowerTube

"SAG" is Natural!

PowerTrak GRP is made of reinforced nylon which has excellent memory and is a good bearing material. When correctly applied, PowerTrak GRP can safely sag and is designed to glide on itself. Amount of sag depends on system length, PowerTrak type and cable/hose package weight.

Figure 1: A short PowerTrak with nominal sag.

Figure 2: Longer PowerTrak showing moderate sag.

Figure 3: A very long PowerTrak gliding on itself.

A tray system helps guide such long systems.
See "Guide Trays".

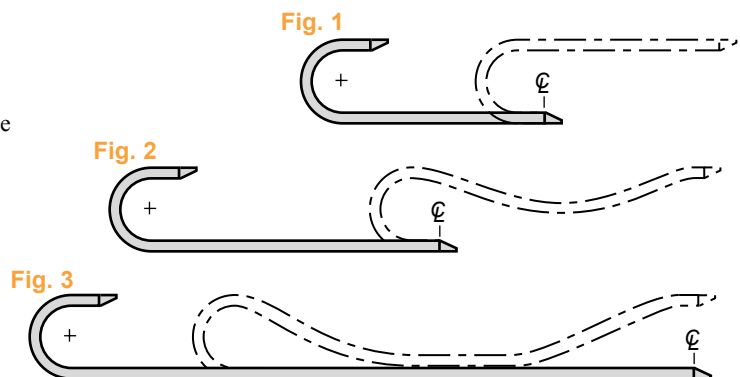

Lateral Forces

When significant lateral forces are present (on a crane bridge, for example, when the crane moves along the runway) PowerTrak GRP may need side support. This is especially true on longer travels. A guide tray is often the solution (see "Guide Trays"). Contact us for specific recommendations.

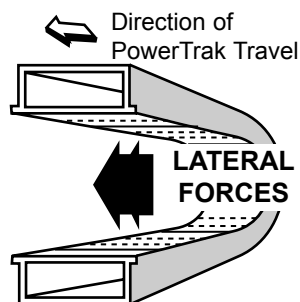

Speed

Generally, short lengths of self-supported PowerTrak can travel at high rates of speed and acceleration. For longer travels, a guide tray should be used. When speeds exceed 600 fpm and/or acceleration exceeds 10fps², please consult factory.

Step 3

DETERMINING LENGTH

You need enough PowerTrak GRP to cover:

- The Total Travel (TT) of your machine, for one-way payout (Fig 1), or 1/2 the Total Travel, for two-way payout (fig 2).
- Plus the length to form the PowerTrak curve (L) from [Quick Reference Selection Guide](#) (fig 3).

The most cost-effective way to use PowerTrak is to locate the trak's fixed end (cable/hose source) at the CENTER of the machine travel, allowing pay-out in two (2) directions. We refer to this as "Two-way payout", illustrated in figure 2. Travel potential for the same length PowerTrak is DOUBLED when two-way payout is used. In the same way, you minimize the cost of cables and hoses – they need be only about HALF as long as your total travel (TT).

Opposed Travel application (Fig 4) does not shorten the length of PowerTrak required on each side (both must be 1/2 total travel). Rather, an Opposed Travel application is two similar PowerTraks installed in opposite directions. This application may allow use of a smaller trak style or allow separation of cables and hoses servicing a single machine.

See [Quick Reference Selection Guide](#) for "L" (curve lengths) of various PowerTrak styles.

<p>ONE-WAY PAYOUT</p> <p>$TT \text{ (ft.)} + L \text{ (ft.)}$</p>	<p>Length to order:</p>	<p>TWO-WAY PAYOUT</p> <p>$\frac{TT \text{ (ft.)}}{2} + L \text{ (ft.)}$</p>
---	--------------------------------	---

FIG. 1 STANDARD travel with ONE-WAY payout

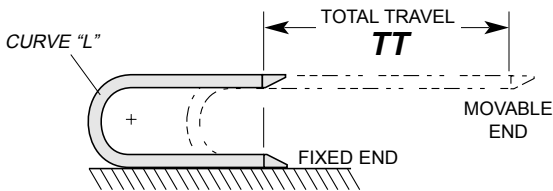

FIG. 2 STANDARD travel with TWO-WAY payout

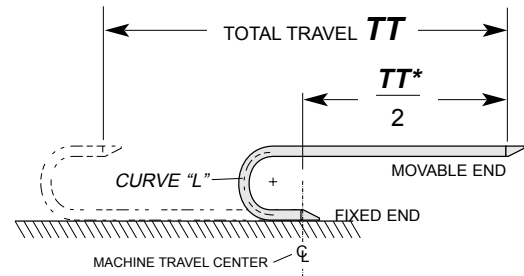

FIG. 3

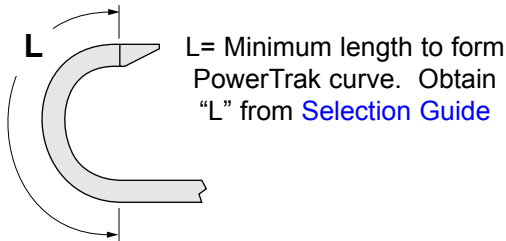
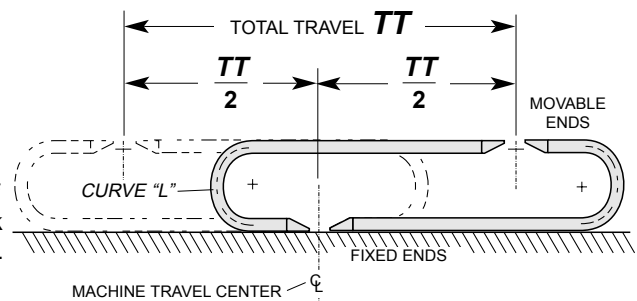

FIG. 4

OPPOSED travel with TWO-WAY payout



On OPPOSED TRAVEL applications, length of track **must be identical** for both PowerTraks. Style of PowerTrak, including number of dividers, may differ between the two PowerTraks so as to accommodate different cable and hose arrangements. For long travels, use of a [GUIDE TRAY](#) is highly recommended. If [GUIDE TRAY](#) is used, trak styles (outside widths) must also be identical for the two PowerTraks.

101P

GLEASON PowerTrak[®] GRP

- COMPACT DESIGN
- NON-CONDUCTIVE, RESISTS CORROSION
- RADII AVAILABLE = 1.43" & 1.91"
- TOTAL TRAVEL SELF-SUPPORTED NO SAG = 4.0 FT^①
- TOTAL TRAVEL SELF-SUPPORTED W/SAG = 5.5 FT^①
- MAX. CABLE/HOSE O.D. = 0.62"

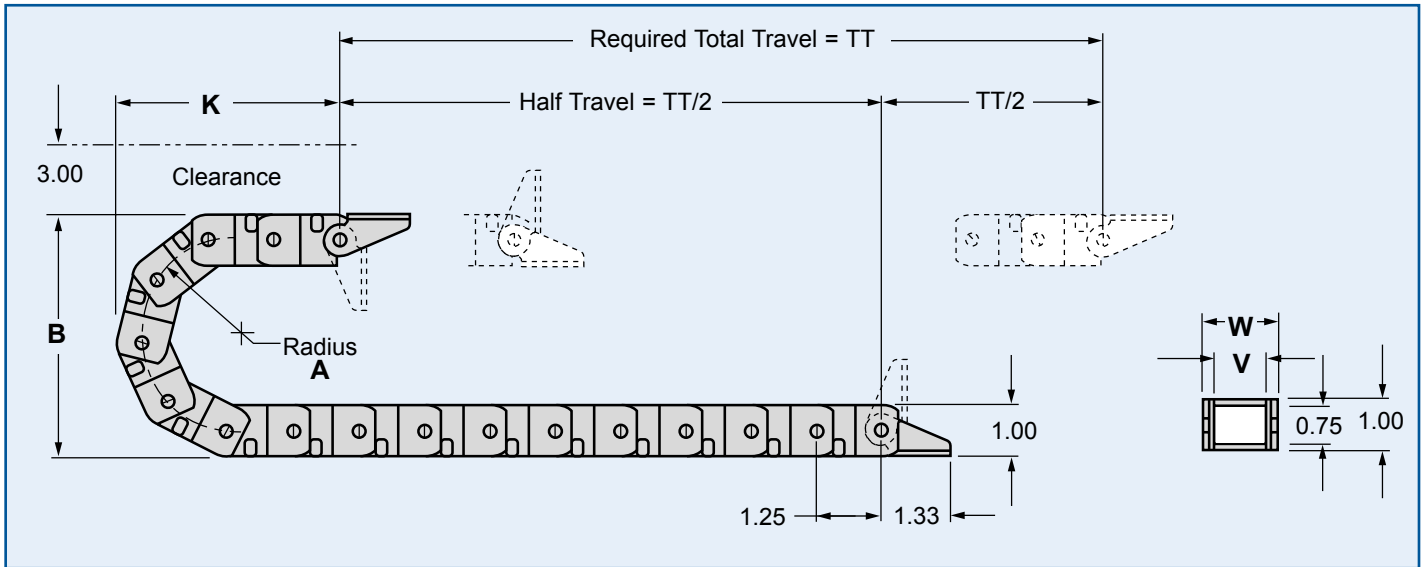

101P Dimensions IN INCHES UNLESS OTHERWISE INDICATED

Model Number	RADIUS A	HEIGHT B	MIN. K	CURVE L ^④	WINDOW V	CABLE MAX. O.D.	WIDTH W	WEIGHT (lbs/ft) ^⑤
101P-I-1.4	1.43	3.86	5.68	1.0 ft.	0.59	0.34 in.	1.03	0.20
101P-II-1.4	1.43	3.86	5.68	1.0 ft.	1.00	0.62 in.	1.44	0.25
101P-II-1.9	1.91	4.82	5.41	1.0 ft.	1.00	0.62 in.	1.44	0.25

Length to order^③ =

$$\frac{TT}{2} + L$$

NOTES:

- ① Total Travel is nominal, based on standard travel with cable/hose pkg weight of 0.5 lbs/ft., and may vary with environment.
- ② For standard travel, i.e. two-way payout as pictured above.
- ③ L = Minimum length in FEET to form PowerTrak GRP curve.
- ④ Weight per foot UNLOADED.

Mounting Bracket Kits

DIMENSIONS IN INCHES

- Each bracket kit contains one MALE bracket, typically installed on the fixed end and one FEMALE bracket, typically installed on the moving end.

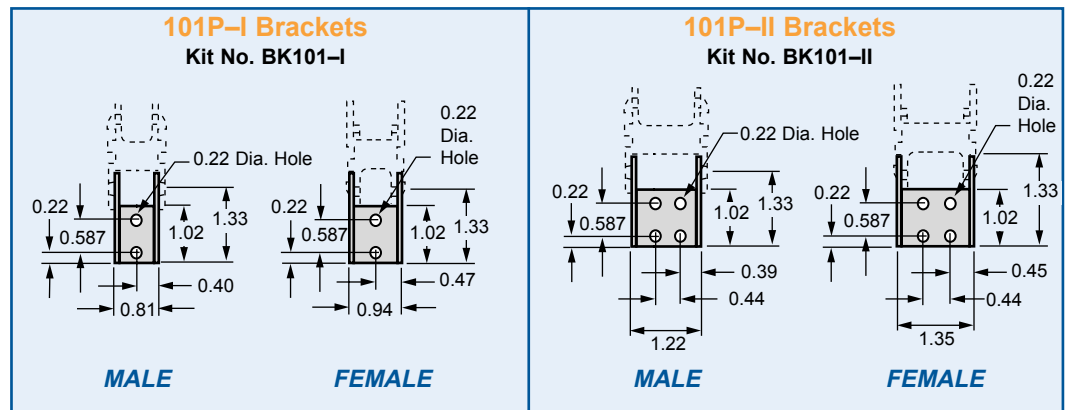

Featuring SNAP-OUT Carrier Bars

- COMPACT DESIGN
- NON-CONDUCTIVE, RESISTS CORROSION
- RADII AVAILABLE = 1.43" & 1.91"
- TOTAL TRAVEL SELF-SUPPORTED NO SAG = 4.0 FT^①
- TOTAL TRAVEL SELF-SUPPORTED W/SAG = 5.5 FT^①
- MAX. CABLE/HOSE O.D. = 0.62"

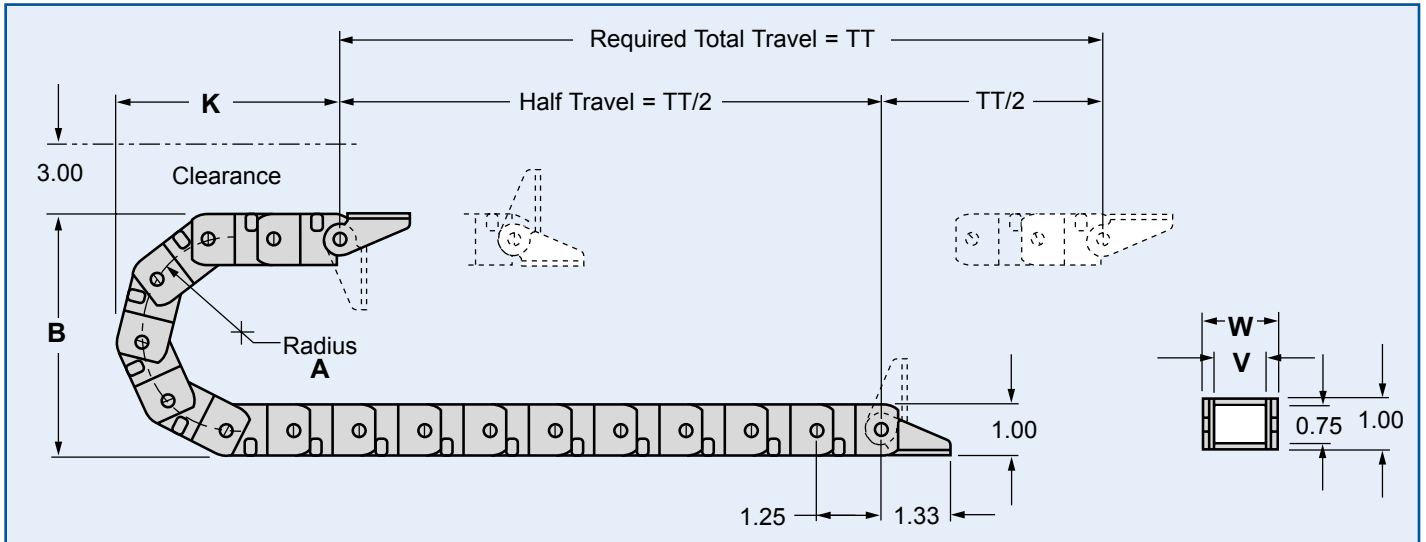

101PS Dimensions IN INCHES UNLESS OTHERWISE INDICATED

Model Number	RADIUS A	HEIGHT B	MIN. K	CURVE L ^④	WINDOW V	CABLE MAX. O.D.	WIDTH W	WEIGHT (lbs/ft) ^⑤
101P-IS-1.4	1.43	3.86	5.68	1.0 ft.	0.59	0.34 in.	1.03	0.20
101P-IIS-1.4	1.43	3.86	5.68	1.0 ft.	1.00	0.62 in.	1.44	0.25
101P-IIS-1.9	1.91	4.82	5.41	1.0 ft.	1.00	0.62 in.	1.44	0.25

Length to order^③ =

$$\frac{TT}{2} + L$$

NOTES:

- ① Total Travel is nominal, based on standard travel with cable/hose pkg weight of 0.5 lbs/ft., and may vary with environment.
- ② For standard travel, i.e. two-way payout as pictured above.
- ③ L = Minimum length in FEET to form PowerTrak GRP curve.
- ④ Weight per foot UNLOADED.

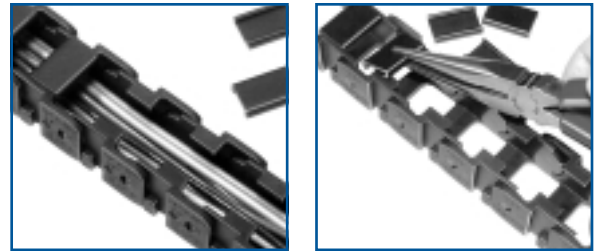

Unique "SNAP-OUT" Carrier Bar

Speeds cable/hose installation. No tools required to snap bars in to hold cables/hoses firmly in place. Bars snap out easily with a pliers.

Mounting Bracket Kits

DIMENSIONS IN INCHES

- Each bracket kit contains one MALE bracket, typically installed on the fixed end and one FEMALE bracket, typically installed on the moving end.

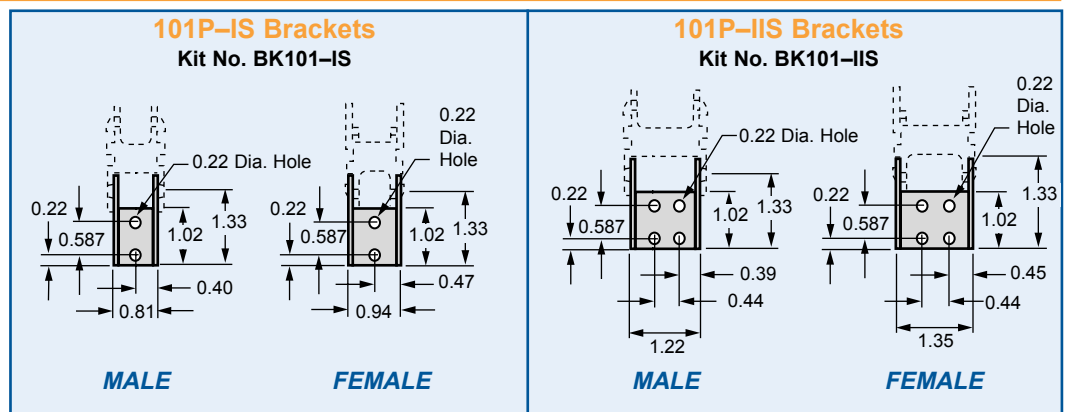

132P

GLEASON PowerTrak GRP

- COMPACT DESIGN
- SOLID, SNAP-TOGETHER LINKS
- NON-CONDUCTIVE, RESISTS CORROSION
- RADII AVAILABLE = 2.05", & 3.70"

- TOTAL TRAVEL SELF-SUPPORTED NO SAG = 9.0 FT^①
- TOTAL TRAVEL SELF-SUPPORTED W/SAG = 11.0 FT^①
- TOTAL TRAVEL W/GUIDE TRAY = 100 FT^②
- MAX. CABLE/HOSE O.D. = 0.82"

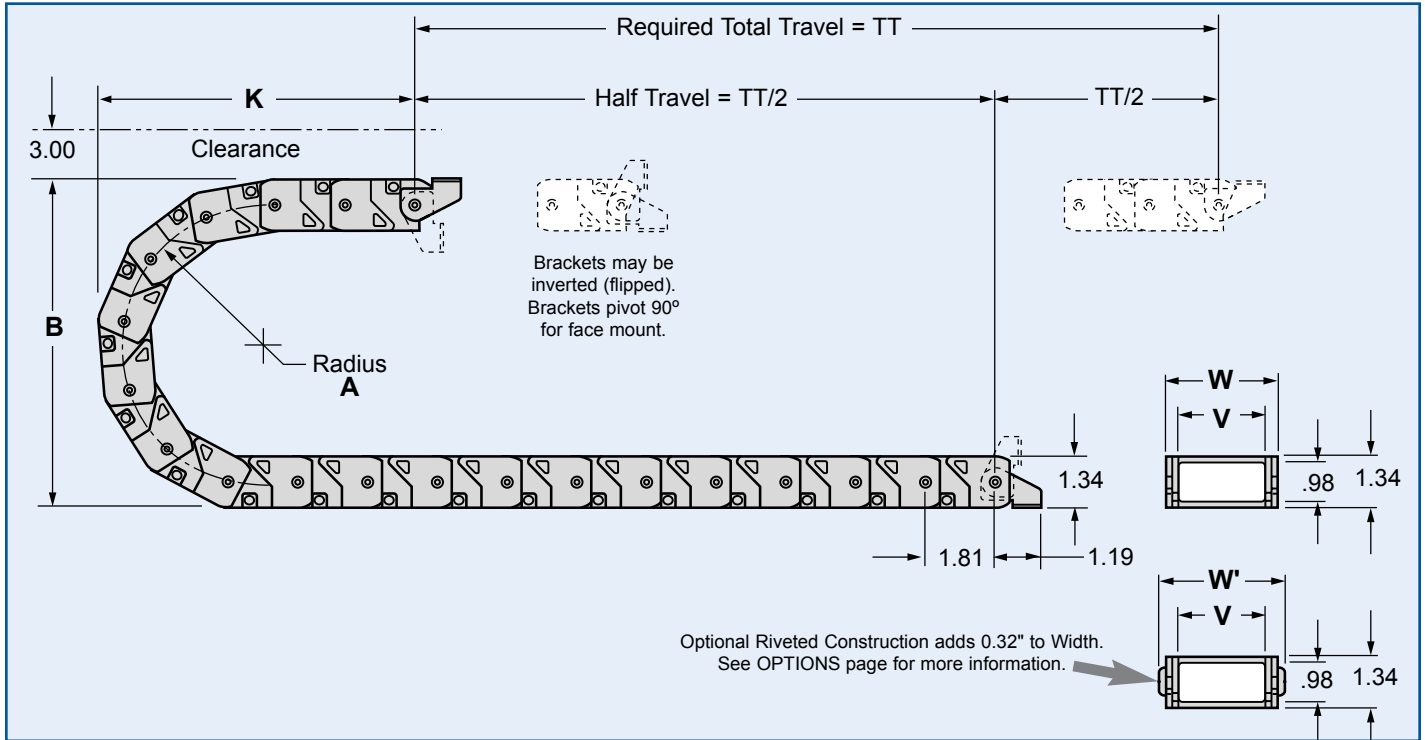

132P Dimensions IN INCHES UNLESS OTHERWISE INDICATED

Model Number	RADIUS A	HEIGHT B	MIN. K	CURVE L ^④	WINDOW V	WIDTH W	WIDTH W'	WEIGHT (lbs/ft) ^⑤
132P-I-2.0	2.05	5.44	5.50	1.0 ft.	1.50	2.12	2.44	0.44
132P-I-3.7	3.70	8.74	7.56	1.5 ft.	1.50	2.12	2.44	0.44
132P-II-2.0	2.05	5.44	5.50	1.0 ft.	2.28	2.91	3.23	0.48
132P-II-3.7	3.70	8.74	7.56	1.5 ft.	2.28	2.91	3.23	0.48
132P-III-2.0	2.05	5.44	5.50	1.0 ft.	3.08	3.70	4.02	0.54
132P-III-3.7	3.70	8.74	7.56	1.5 ft.	3.08	3.70	4.02	0.54

Length to order ^③ =

$$\frac{TT}{2} + L$$

NOTES:

- ① Total Travel is nominal, based on standard travel with cable/hose pkg weight of 0.5 lbs/ft., and may vary with environment. GREATER TRAVELS CAN BE ACHIEVED if PowerTrak is allowed to glide on itself within a guide tray.
- ② GREATER TRAVELS IN TRAYS CAN BE ACHIEVED. Consult the factory.

- ③ For standard travel, i.e. two-way payout as pictured above.
- ④ L = Minimum length in FEET to form PowerTrak GRP curve.
- ⑤ Weight per foot UNLOADED.

Mounting Bracket Kits

DIMENSIONS IN INCHES

Model	Kit Number
132P-I	BK132-I
132P-II	BK132-II
132P-III	BK132-III

- Each bracket kit contains one MALE bracket, typically installed on the fixed end and one FEMALE bracket, typically installed on the moving end.

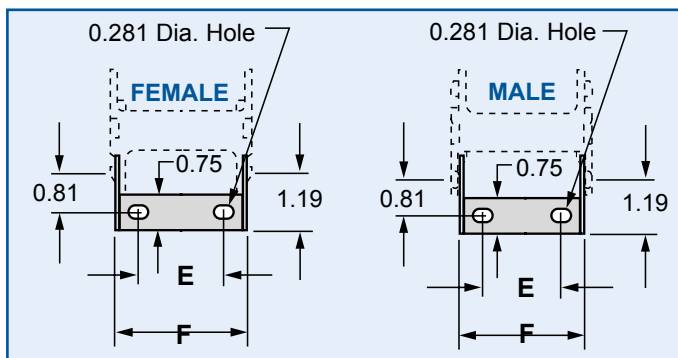

FEMALE BRKT DIMENSIONS

Model	E	F
132P-I	0.99	1.97
132P-II	1.78	2.75
132P-III	2.57	3.55

MALE BRKT DIMENSIONS

Model	E	F
132P-I	0.87	1.84
132P-II	1.65	2.62
132P-III	2.44	3.42

162P

GLEASON PowerTrak GRP

- STANDARD DESIGN
- SNAP-TOGETHER LINKS
- NON-CONDUCTIVE, RESISTS CORROSION
- RADII AVAILABLE = 1.91" 3.44" & 7.87"

- TOTAL TRAVEL SELF-SUPPORTED NO SAG = 9.0 FT^①
- TOTAL TRAVEL SELF-SUPPORTED W/SAG = 10.5 FT^①
- TOTAL TRAVEL W/GUIDE TRAY = 100 FT^②
- MAX. CABLE/HOSE O.D. = 0.83"

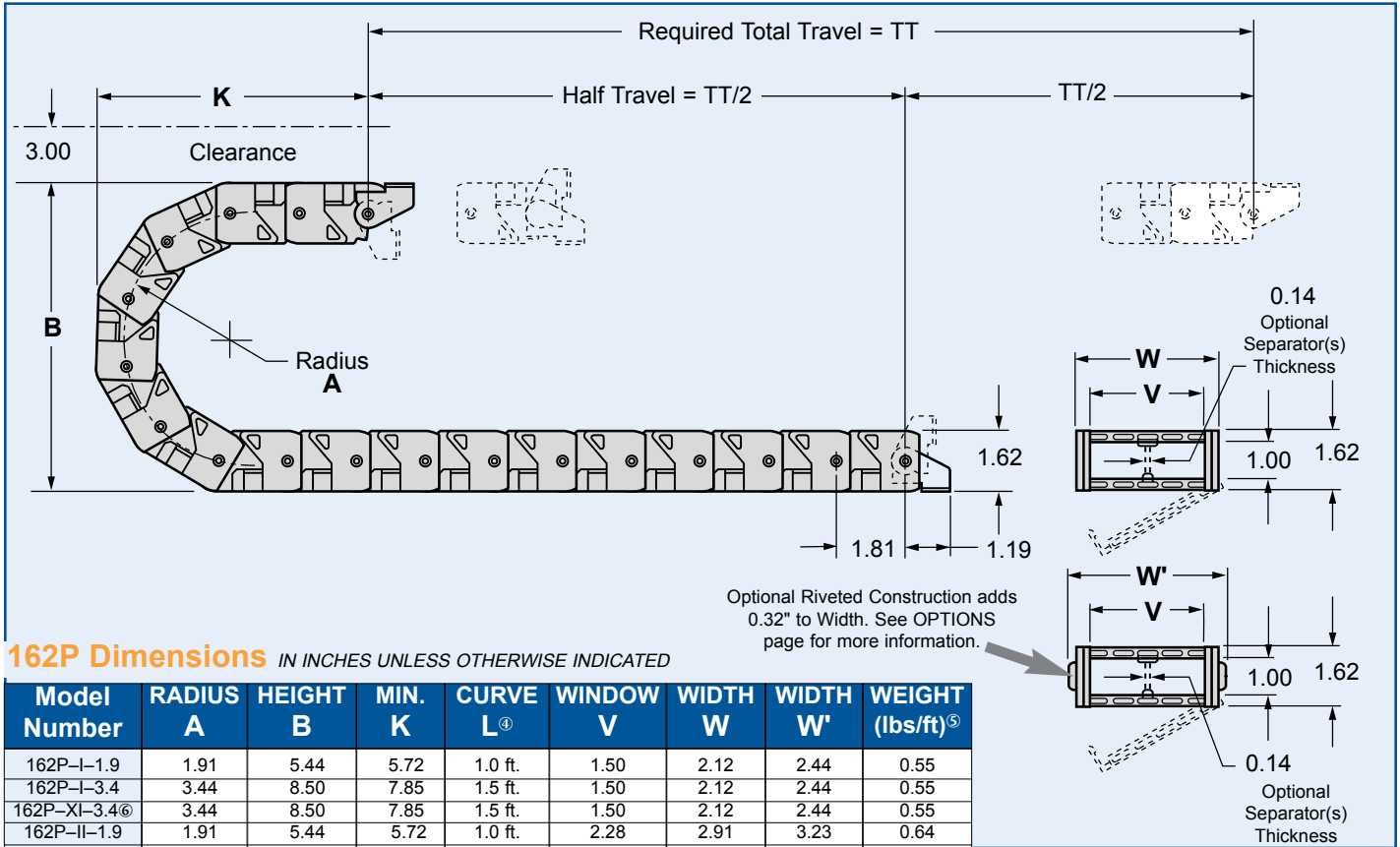

162P Dimensions IN INCHES UNLESS OTHERWISE INDICATED

Model Number	RADIUS A	HEIGHT B	MIN. K	CURVE L ^④	WINDOW V	WIDTH W	WIDTH W'	WEIGHT (lbs/ft) ^⑤
162P-I-1.9	1.91	5.44	5.72	1.0 ft.	1.50	2.12	2.44	0.55
162P-I-3.4	3.44	8.50	7.85	1.5 ft.	1.50	2.12	2.44	0.55
162P-XI-3.4 ^⑥	3.44	8.50	7.85	1.5 ft.	1.50	2.12	2.44	0.55
162P-II-1.9	1.91	5.44	5.72	1.0 ft.	2.28	2.91	3.23	0.64
162P-II-3.4	3.44	8.50	7.85	1.5 ft.	2.28	2.91	3.23	0.64
162P-III-1.9	1.91	5.44	5.72	1.0 ft.	3.08	3.70	4.02	0.74
162P-III-3.4	3.44	8.50	7.85	1.5 ft.	3.08	3.70	4.02	0.74
162P-IV-1.9	1.91	5.44	5.72	1.0 ft.	4.06	4.69	5.01	0.84
162P-IV-3.4	3.44	8.50	7.85	1.5 ft.	4.06	4.69	5.01	0.84
162P-IV-7.87	7.87	17.36	11.32	2.5 ft.	4.06	4.69	5.01	0.84

Length to order^③ =

$$\frac{TT}{2} + L$$

NOTES:

- Total Travel is nominal, based on standard travel with cable/hose pkg weight of 0.5 lbs/ft., and may vary with environment. GREATER TRAVELS CAN BE ACHIEVED if PowerTrak is allowed to glide on itself within a guide tray.
- GREATER TRAVELS IN TRAYS CAN BE ACHIEVED. Consult the factory.
- For standard travel, i.e. two-way payout as pictured above.
- L = Minimum length in FEET to form PowerTrak GRP curve.
- Weight per foot UNLOADED.
- Flip-Tops on 162P-XI open to the INSIDE rather than the outside, as on all other 162P models.

Mounting Bracket Kits

DIMENSIONS IN INCHES

Model	Kit Number
162P-I	BK162-I
162P-XI	BK162-XI
162P-II	BK162-II
162P-III	BK162-III
162P-IV	BK162-IV

- Each bracket kit contains one MALE bracket, typically installed on the fixed end and one FEMALE bracket, typically installed on the moving end.

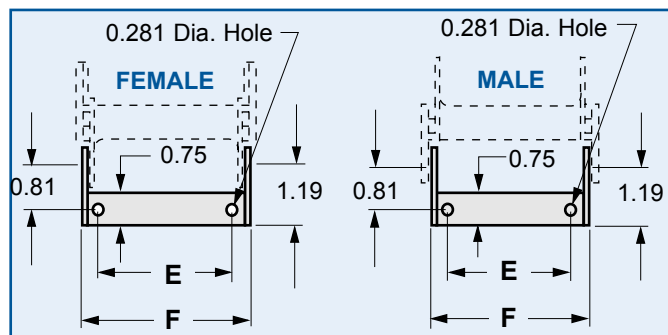

FEMALE BRKT DIMENSIONS

Model	E	F
162P-I	0.99	1.97
162P-XI	0.99	1.97
162P-II	1.78	2.75
162P-III	2.57	3.55
162P-IV	3.56	4.53

MALE BRKT DIMENSIONS

Model	E	F
162P-I	0.87	1.84
162P-XI	0.87	1.84
162P-II	1.65	2.63
162P-III	2.44	3.42
162P-IV	3.47	4.41

252P

GLEASON PowerTrak GRP

- STANDARD DESIGN
- SNAP-TOGETHER LINKS WITH FLIP-TOPS[®]
- VERTICAL SEPARATORS AVAILABLE
- RADII AVAILABLE = 2.75", 3.40", 4.78", 7.73", 10.73", 11.67"
- TOTAL TRAVEL SELF-SUPPORTED NO SAG = 13.5 FT^①
- TOTAL TRAVEL SELF-SUPPORTED W/SAG = 17.0 FT^①
- TOTAL TRAVEL W/GUIDE TRAY = 200 FT^②
- MAX. CABLE/HOSE O.D. = 1.46"

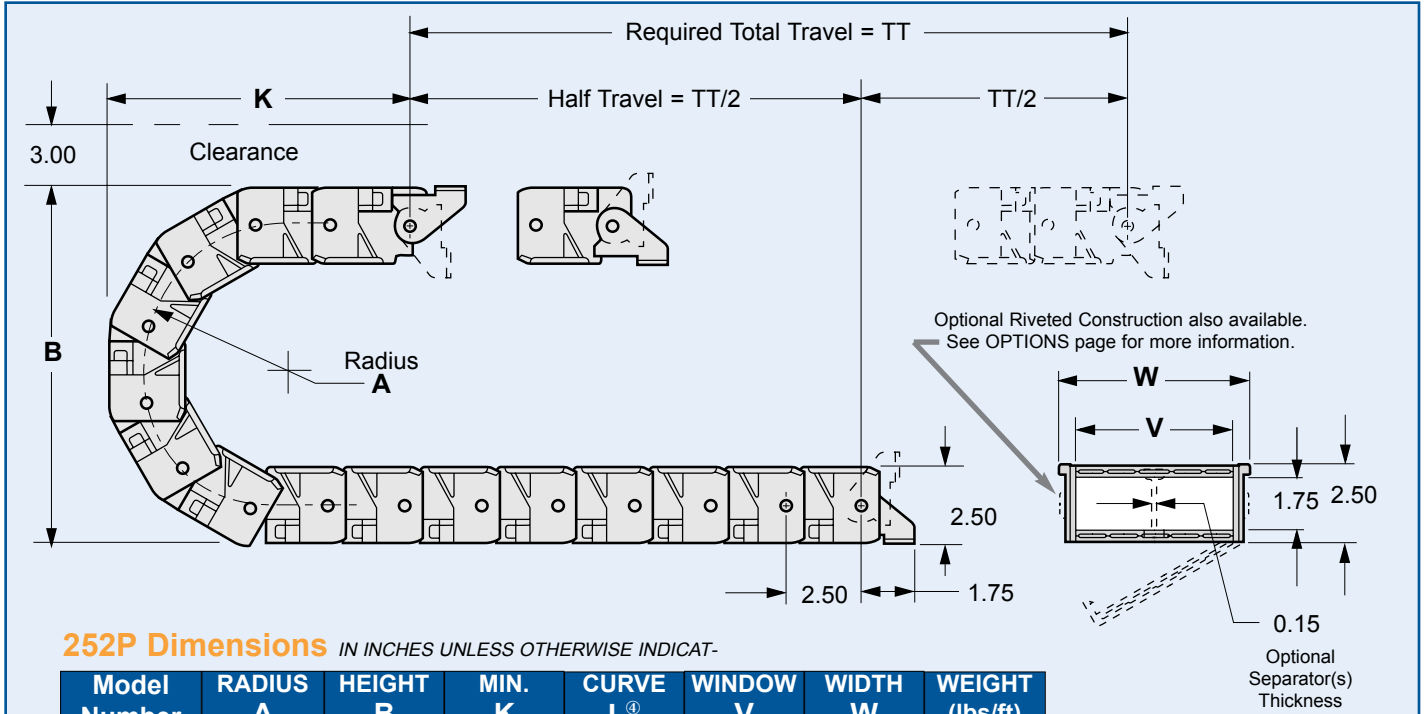

252P Dimensions IN INCHES UNLESS OTHERWISE INDICATED

Model Number	RADIUS A	HEIGHT B	MIN. K	CURVE L ^④	WINDOW V	WIDTH W	WEIGHT (lbs/ft)
252P-I-3.4	3.40	9.30	8.31	1.5 ft.	2.60	3.70	1.00
252P-I-4.7	4.78	12.06	10.52	2.0 ft.	2.60	3.70	1.00
252P-I-7.7	7.73	17.96	11.84	2.5 ft.	2.60	3.70	1.00
252P-II-3.4	3.40	9.30	8.31	1.5 ft.	4.25	5.36	1.20
252P-II-4.7	4.78	12.06	10.52	2.0 ft.	4.25	5.36	1.20
252P-II-7.7	7.73	17.96	11.84	2.5 ft.	4.25	5.36	1.20
252P-II-10.73	10.73	23.96	13.13	3.0 ft.	4.25	5.36	1.20
252P-II-11.6	11.67	25.84	15.59	3.5 ft.	4.25	5.36	1.20
252P-IIA ^⑤	2.75	8.00	8.68	1.5 ft.	4.25	5.36	1.13
252P-III-4.7	4.78	12.06	10.52	2.0 ft.	6.60	7.70	1.50
252P-III-7.74	7.73	17.96	11.84	2.5 ft.	6.60	7.70	1.50

Length to order^③ =

$$\frac{TT}{2} + L$$

NOTES:

- ① Total Travel is nominal, based on standard travel with cable/hose pkg weight of 0.5 lbs/ft., and may vary with environment. GREATER TRAVELS CAN BE ACHIEVED if PowerTrak is allowed to glide on itself within a guide tray.
- ② GREATER TRAVELS IN TRAYS CAN BE ACHIEVED. Consult the factory.
- ③ For standard travel, i.e. two-way payout as pictured above.
- ④ L = Minimum length in FEET to form PowerTrak GRP curve.
- ⑤ Type 252P-IIA is a SOLID LINK DESIGN; Flip-Tops NOT available.

Mounting Bracket Kits

DIMENSIONS IN INCHES

Model	Kit Number
252P-I	BK252-I
252P-II	BK252-II
252P-IIA	BK252-II
252P-III	BK252-III

• Each bracket kit contains one MALE bracket, typically installed on the fixed end and one FEMALE bracket, typically installed on the moving end.

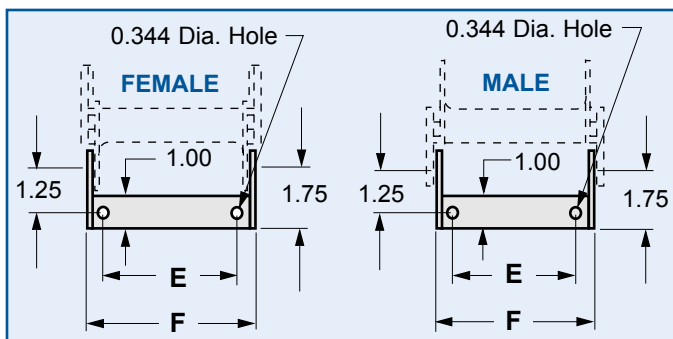

FEMALE BRKT DIMENSIONS

Model	E	F
252P-I	2.08	3.21
252P-II	3.74	4.87
252P-IIA	3.74	4.87
252P-III	6.08	7.21

MALE BRKT DIMENSIONS

Model	E	F
252P-I	1.80	3.03
252P-II	3.46	4.69
252P-IIA	3.46	4.69
252P-III	5.80	7.03

263P

GLEASON PowerTrak[®] GRP

- HEAVY DUTY DESIGN
- FLIP-OPEN LINKS W/TWO (2) SEPARATORS INCLUDED
- MAX. CABLE/HOSE O.D. = 1.46" ^⑤
- RADII "A" AVAILABLE = 3.67", 7.42" & 10.92"
- TOTAL TRAVEL SELF-SUPPORTED NO SAG = 17.0 FT^①
- TOTAL TRAVEL SELF-SUPPORTED W/SAG = 20.0 FT^①
- TOTAL TRAVEL W/GUIDE TRAY = 250 FT^②
- 263P WEIGHT UNLOADED = 2.05 LBS/FT

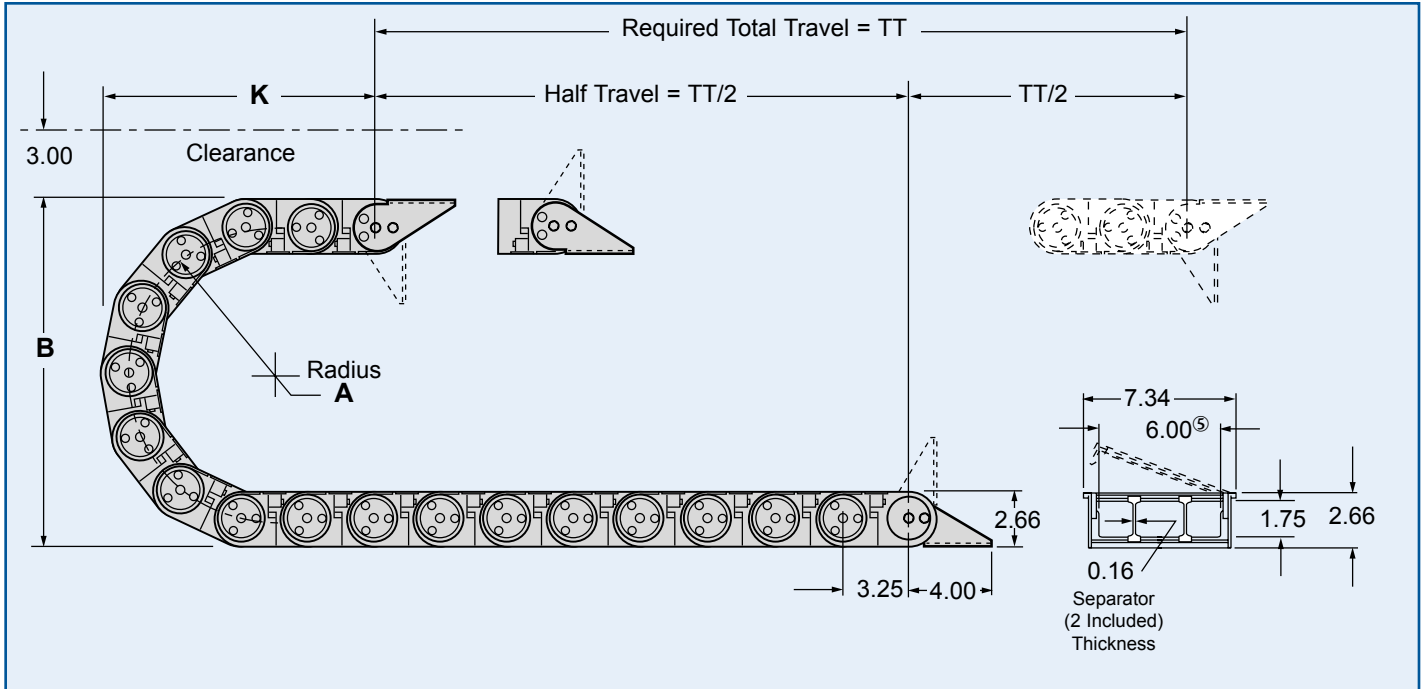

263P Dimensions

IN INCHES UNLESS OTHERWISE INDICATED

Model Number	RADIUS A	HEIGHT B	MIN. K	CURVE L ^④
263P-3.6	3.67	10.00	8.40	1.5 FT.
263P-7.4	7.42	17.50	12.20	2.5 FT.
263P-10.9	10.92	24.50	16.10	3.5 FT.

Length to order ^③ =

$$\frac{TT}{2} + L$$

NOTES:

- ① Total Travel is nominal, based on standard travel with cable/hose pkg weight of 0.5 lbs/ft., and may vary with environment. GREATER TRAVELS CAN BE ACHIEVED if PowerTrak is allowed to glide on itself within a guide tray.
- ② GREATER TRAVELS IN TRAYS CAN BE ACHIEVED. Consult the factory.

- ③ For standard travel, i.e. two-way payout as pictured above.
- ④ L = Minimum length in FEET to form PowerTrak GRP curve.
- ⑤ When Two-Piece Machined Nylon Bar Carrier is used, max. O.D. allowed is 0.89", window width (V) available is 5.37".

Mounting Bracket Kits

DIMENSIONS IN INCHES

KIT No. BK263

Bracket kit for all 263P models

- Model 263P uses a two-piece bracket.
- Each bracket kit contains four (4) bracket halves.
- Specify inboard (standard) or outboard (optional) configuration on order.

Inboard

STANDARD CONFIGURATION

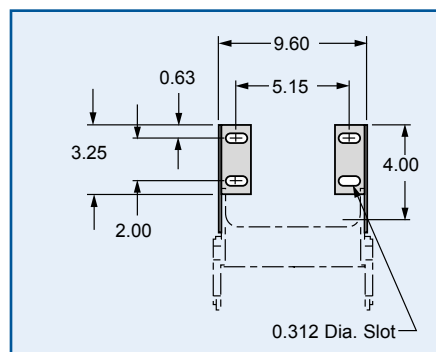

Outboard

OPTIONAL CONFIGURATION

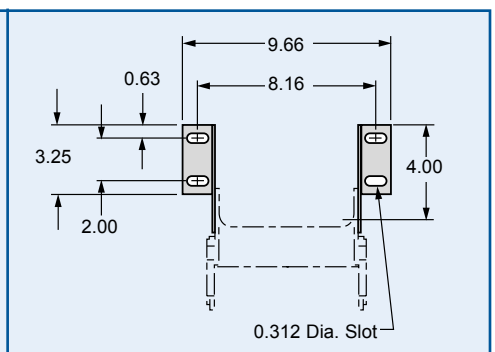

354P

GLEASON PowerTrak[®] GRP

- HEAVY DUTY DESIGN
- FLIP-OPEN LINKS W/TWO (2) SEPARATORS INCLUDED
- MAX. CABLE/HOSE O.D. = 2.12" ^⑤
- RADII "A" AVAILABLE = 6.91" & 11.25"
- TOTAL TRAVEL SELF-SUPPORTED NO SAG = 19.0 FT ^①
- TOTAL TRAVEL SELF-SUPPORTED W/SAG = 23.5 FT ^①
- TOTAL TRAVEL W/GUIDE TRAY = 300 FT ^②
- 354P WEIGHT UNLOADED = 3.06 LBS/FT

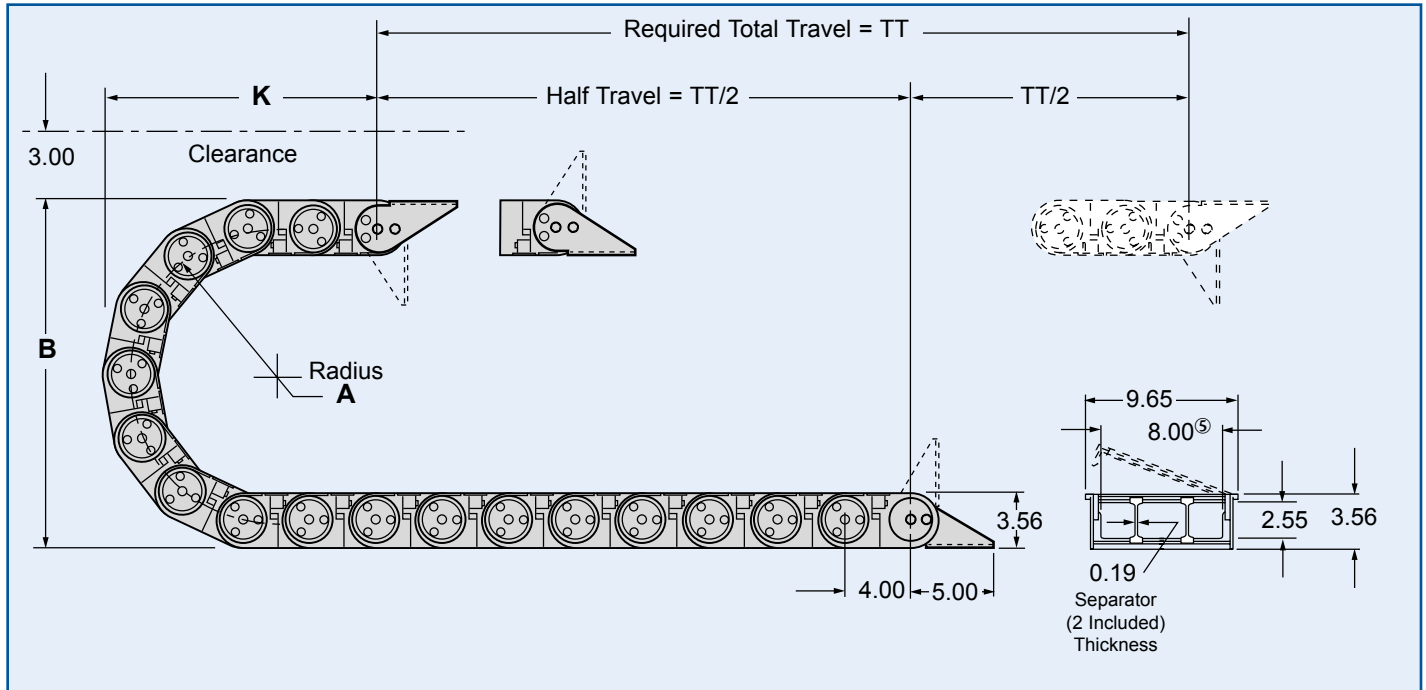

354P Dimensions

IN INCHES UNLESS OTHERWISE INDICATED

Model Number	RADIUS A	HEIGHT B	MIN. K	CURVE L ^④
354P-6.9	6.91	17.30	12.80	2.5 FT
354P-11.2	11.25	26.00	16.30	3.5 FT

Length to order ^③ =

$$\frac{TT}{2} + L$$

NOTES:

- ① Total Travel is nominal, based on standard travel with cable/hose pkg weight of 0.5 lbs/ft., and may vary with environment. GREATER TRAVELS CAN BE ACHIEVED if PowerTrak is allowed to glide on itself within a guide tray.
- ② GREATER TRAVELS IN TRAYS CAN BE ACHIEVED. Consult the factory.
- ③ For standard travel, i.e. two-way payout as pictured above.
- ④ L = Minimum length in FEET to form PowerTrak GRP curve.
- ⑤ When Two-Piece Machined Nylon Bar Carrier is used, max. O.D. allowed is 1.69"; window width (V) available is 7.34".

Mounting Bracket Kits

DIMENSIONS IN INCHES

KIT No. BK354

Bracket kit for all 354P models

- Model 354P uses a two-piece bracket.
- Each bracket kit contains four (4) bracket halves.
- Specify inboard (standard) or outboard (optional) configuration on order.

Inboard

STANDARD CONFIGURATION

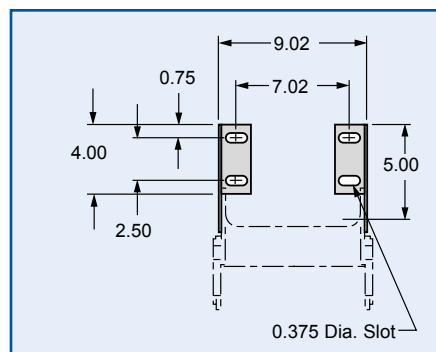

Outboard

OPTIONAL CONFIGURATION

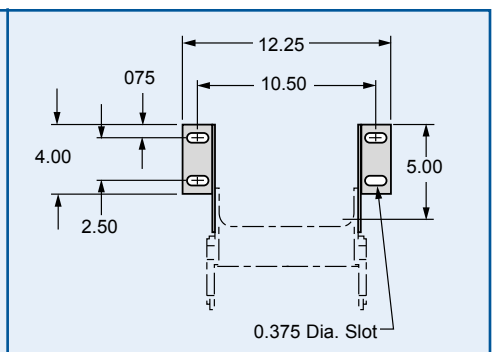

815

GLEASON PowerTube

- COMPACT DESIGN
- SOLID DESIGN, ENCLOSED LINKS
- MAX. CABLE/HOSE O.D. = 0.67"
- RADII "A" AVAILABLE = 2.34"

- TOTAL TRAVEL SELF-SUPPORTED NO SAG = 5.0 FT^①
- TOTAL TRAVEL SELF-SUPPORTED W/SAG = 6.0 FT^①
- TOTAL TRAVEL W/GUIDE TRAY = 60 FT^②
- 815 WEIGHT UNLOADED = 0.62 LBS/FT

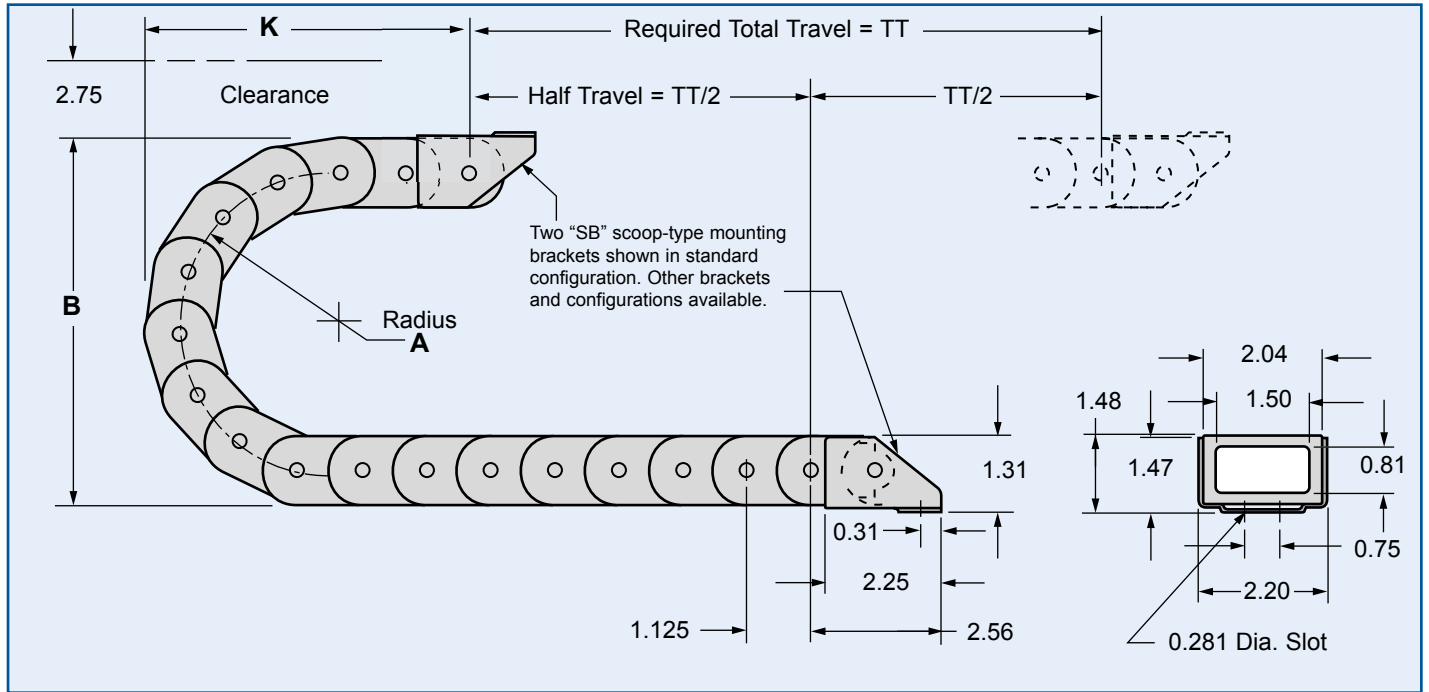

815 Dimensions

IN INCHES UNLESS OTHERWISE INDICATED

Model Number	RADIUS A	HEIGHT B	MIN. K	CURVE L ^④
815-2.3	2.34	6.34	5.32	1.0 FT

Length to order^③ =

$$\frac{TT}{2} + L$$

NOTES:

- ① Total Travel is nominal, based on standard travel with cable/hose pkg weight of 0.5 lbs/ft., and may vary with environment. GREATER TRAVELS CAN BE ACHIEVED if PowerTube is allowed to glide on itself within a guide tray.
- ② GREATER TRAVELS IN TRAYS CAN BE ACHIEVED. Consult the factory.

- ③ For standard travel, i.e. two-way payout as pictured above.
- ④ L = Minimum length in FEET to form PowerTube curve.

Mounting Bracket Kits

DIMENSIONS IN INCHES

• "SB" SCOOP-TYPE BRACKETS SHOWN ON DIMENSIONAL DRAWING ABOVE IN STANDARD CONFIGURATION. Virtually any combination of SB & TB brackets possible.

"SB" SCOOP-TYPE BRACKETS

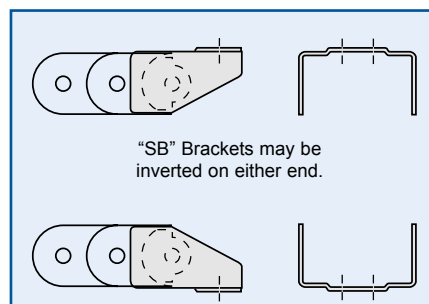

"TB" FLANGE-TYPE BRACKETS

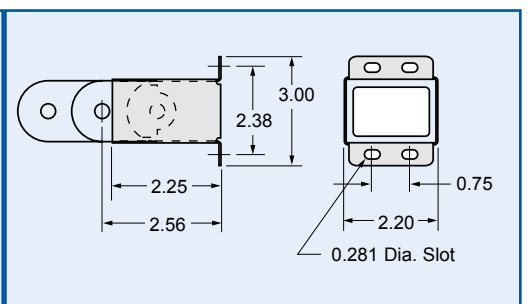

1020

GLEASON PowerTube

- COMPACT DESIGN
- SOLID DESIGN, ENCLOSED LINKS
- MAX. CABLE/HOSE O.D. = 0.83"
- RADII "A" AVAILABLE = 3.25" & 5.88"

- TOTAL TRAVEL SELF-SUPPORTED NO SAG = 7.0 FT^①
- TOTAL TRAVEL SELF-SUPPORTED W/SAG = 8.5 FT^①
- TOTAL TRAVEL W/GUIDE TRAY = 100 FT^②
- 1020 WEIGHT UNLOADED = 0.83 LBS/FT

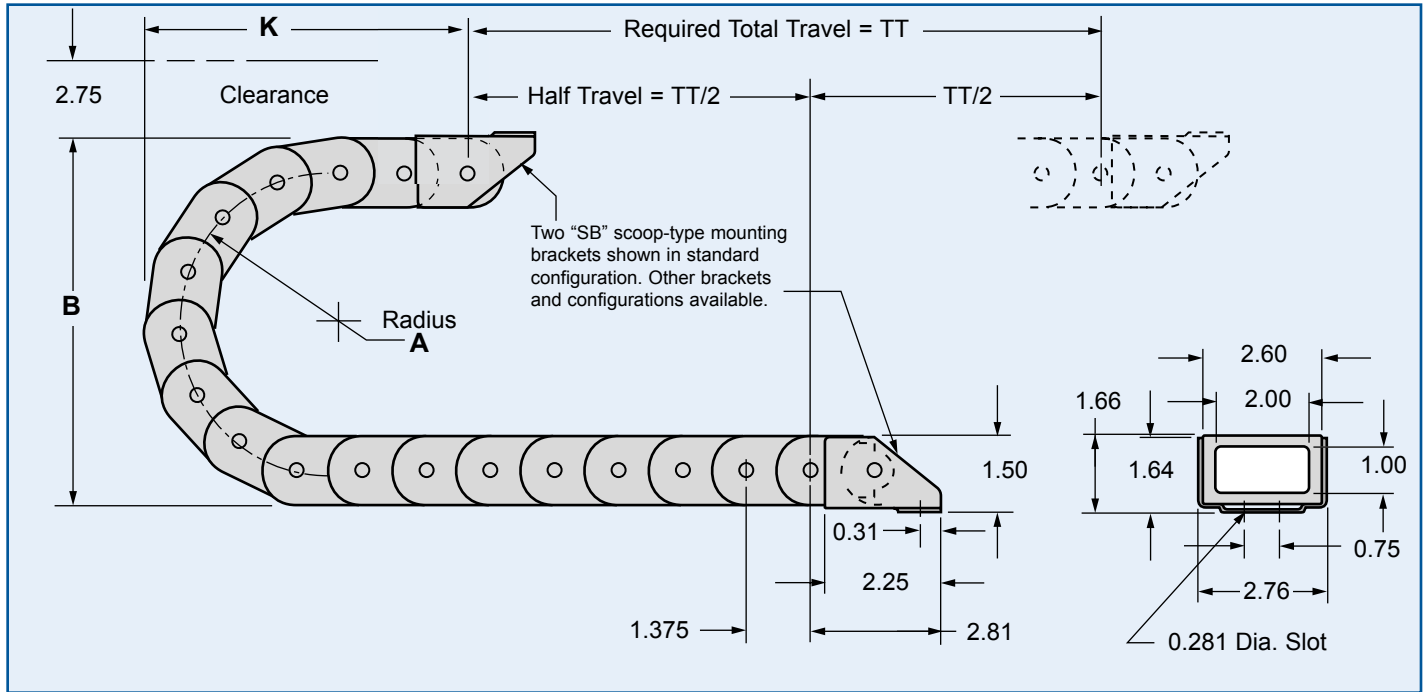

1020 Dimensions

IN INCHES UNLESS OTHERWISE INDICATED

Model Number	RADIUS A	HEIGHT B	MIN. K	CURVE L ^④
1020-3.2	3.25	8.34	7.89	1.5 FT
1020-5.8	5.88	13.61	9.39	2.0 FT

Length to order^③ =

$$\frac{TT}{2} + L$$

NOTES:

- ① Total Travel is nominal, based on standard travel with cable/hose pkg weight of 0.5 lbs/ft., and may vary with environment. GREATER TRAVELS CAN BE ACHIEVED if PowerTube is allowed to glide on itself within a guide tray.
- ② GREATER TRAVELS IN TRAYS CAN BE ACHIEVED. Consult the factory.

- ③ For standard travel, i.e. two-way payout as pictured above.
- ④ L = Minimum length in FEET to form PowerTube curve.

Mounting Bracket Kits

DIMENSIONS IN INCHES

• "SB" SCOOP-TYPE BRACKETS SHOWN ON DIMENSIONAL DRAWING ABOVE IN STANDARD CONFIGURATION. Virtually any combination of SB & TB brackets possible.

"SB" SCOOP-TYPE BRACKETS

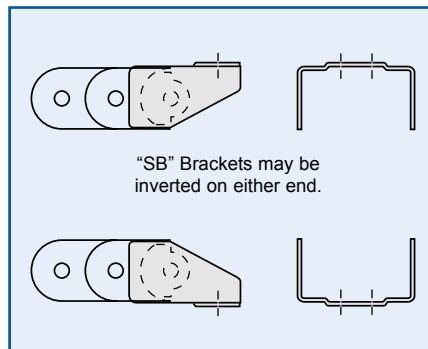

"TB" FLANGE-TYPE BRACKETS

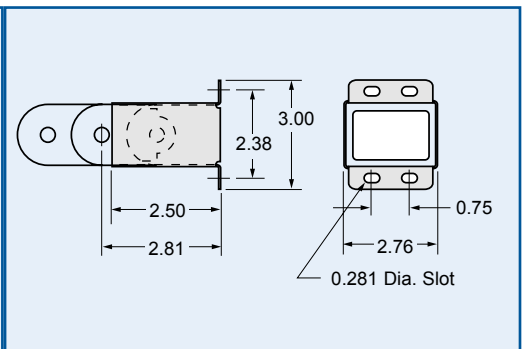

1530

GLEASON PowerTube

- COMPACT DESIGN
- SOLID DESIGN, ENCLOSED LINKS
- MAX. CABLE/HOSE O.D. = 1.25
- RADII "A" AVAILABLE = 4.12" & 7.75"
- TOTAL TRAVEL SELF-SUPPORTED NO SAG = 9.5 FT^①
- TOTAL TRAVEL SELF-SUPPORTED W/SAG = 11.5 FT^①
- TOTAL TRAVEL W/GUIDE TRAY = 150 FT^②
- 1530 WEIGHT UNLOADED = 1.48 LBS/FT

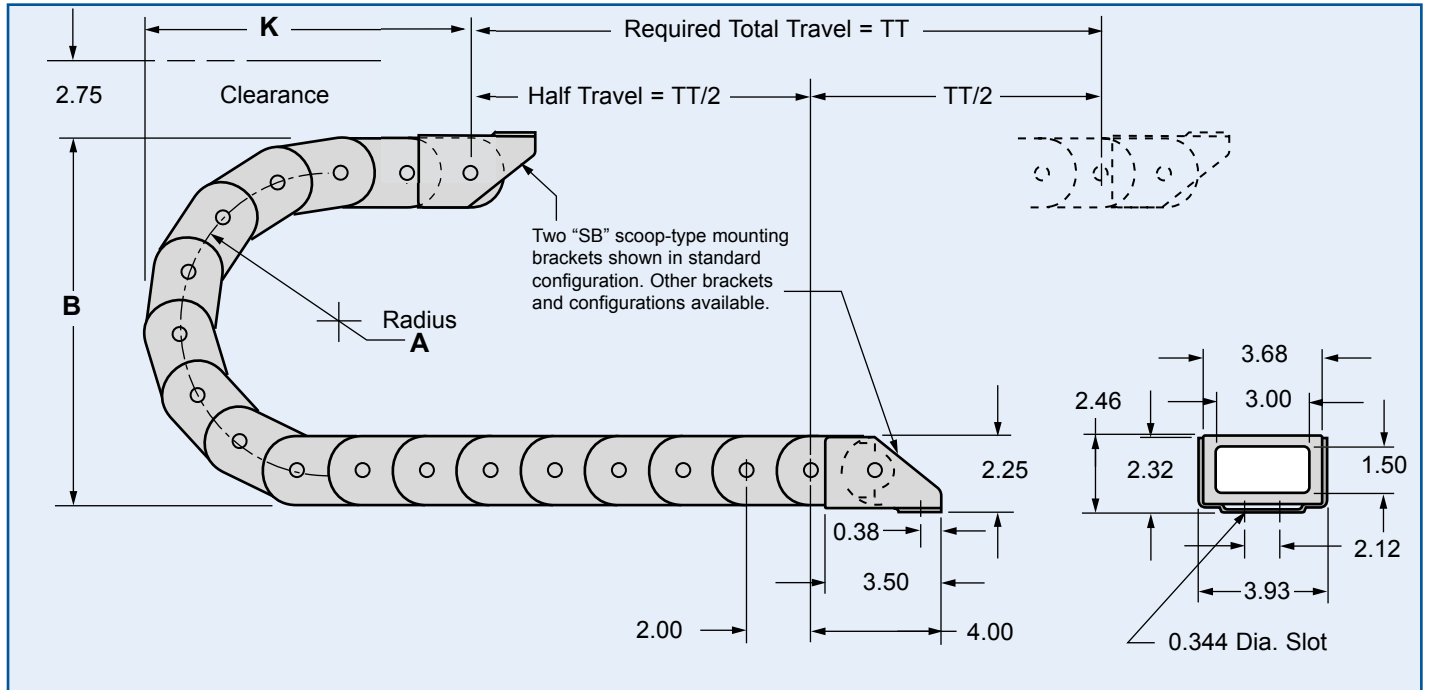

1530 Dimensions

IN INCHES UNLESS OTHERWISE INDICATED

Model Number	RADIUS A	HEIGHT B	MIN. K	CURVE L ^④
1530-4.1	4.12	10.92	10.77	2.0 FT
1530-7.7	7.75	18.18	14.70	3.0 FT

Length to order^③ =

$$\frac{TT}{2} + L$$

NOTES:

- ① Total Travel is nominal, based on standard travel with cable/hose pkg weight of 0.5 lbs/ft., and may vary with environment. GREATER TRAVELS CAN BE ACHIEVED if PowerTube is allowed to glide on itself within a guide tray.
- ② GREATER TRAVELS IN TRAYS CAN BE ACHIEVED. Consult the factory.
- ③ For standard travel, i.e. two-way payout as pictured above.
- ④ L = Minimum length in FEET to form PowerTube curve.

Mounting Bracket Kits

DIMENSIONS IN INCHES

• "SB" SCOOP-TYPE BRACKETS SHOWN ON DIMENSIONAL DRAWING ABOVE IN STANDARD CONFIGURATION. Virtually any combination of SB & TB brackets possible.

"SB" SCOOP-TYPE BRACKETS

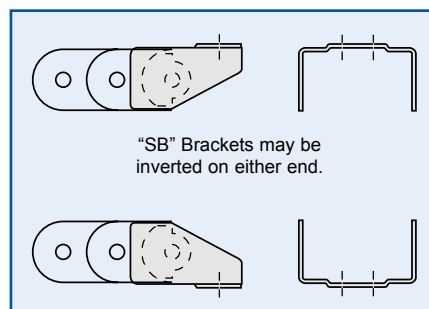

"TB" FLANGE-TYPE BRACKETS

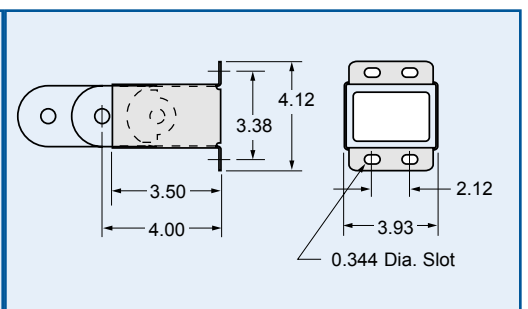

2045

GLEASON PowerTube

- COMPACT DESIGN
- SOLID DESIGN, ENCLOSED LINKS
- MAX. CABLE/HOSE O.D. = 1.67"
- RADII "A" AVAILABLE = 5.88" & 8.38"
- TOTAL TRAVEL SELF-SUPPORTED NO SAG = 11.5 FT^①
- TOTAL TRAVEL SELF-SUPPORTED W/SAG = 14.5 FT^①
- TOTAL TRAVEL W/GUIDE TRAY = 200 FT^②
- 2045 WEIGHT UNLOADED = 2.20 LBS/FT

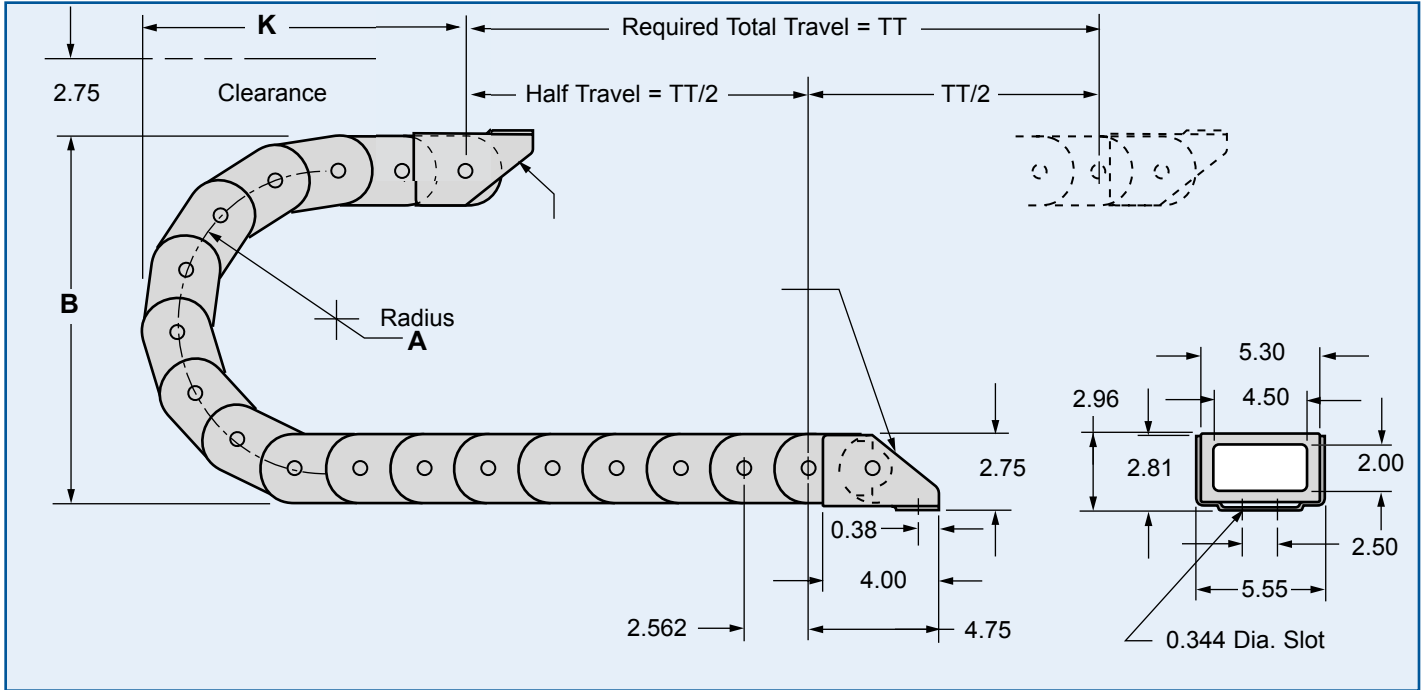

2045 Dimensions

IN INCHES UNLESS OTHERWISE INDICATED

Model Number	RADIUS A	HEIGHT B	MIN. K	CURVE L ^④
2045-5.8	5.88	14.94	13.02	2.5 FT
2045-8.3	8.38	19.94	17.59	3.5 FT

Length to order^③ =

$$\frac{TT}{2} + L$$

NOTES:

- ① Total Travel is nominal, based on standard travel with cable/hose pkg weight of 0.5 lbs/ft., and may vary with environment. GREATER TRAVELS CAN BE ACHIEVED if PowerTube is allowed to glide on itself within a guide tray.
- ② GREATER TRAVELS IN TRAYS CAN BE ACHIEVED. Consult the factory.

- ③ For standard travel, i.e. two-way payout as pictured above.
- ④ **L** = Minimum length in FEET to form PowerTube curve.

Mounting Bracket Kits

DIMENSIONS IN INCHES

- "SB" SCOOP-TYPE BRACKETS SHOWN ON DIMENSIONAL DRAWING ABOVE IN STANDARD CONFIGURATION. Virtually any combination of SB & TB brackets possible.

"SB" SCOOP-TYPE BRACKETS

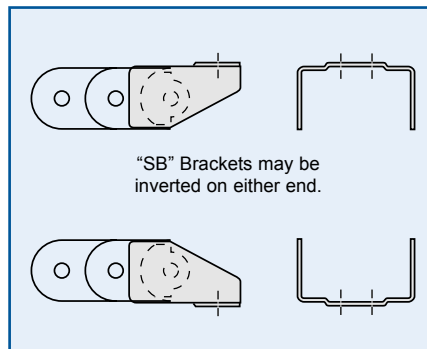

"TB" FLANGE-TYPE BRACKETS

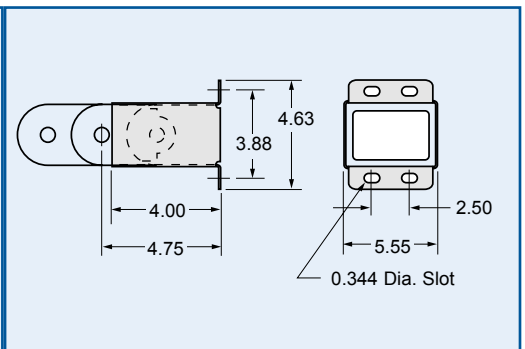

Cable/hose Anchor Strip

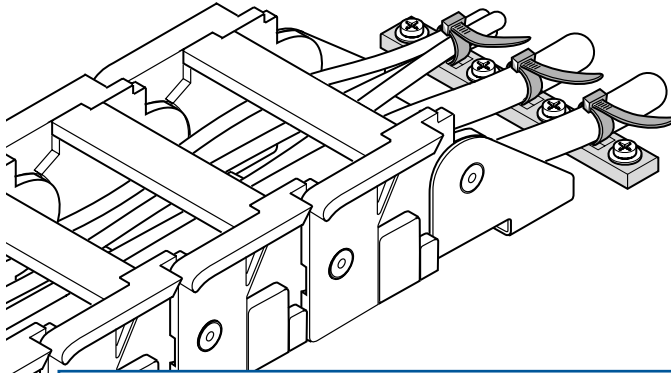

- Affixes hoses or cables at ends of trak to prevent undue wear or stress.
- For use on smaller nylon or steel trak.
- One size. Fits 0.19"–1.50" o.d. cable/hose or bundle.
- Each kit includes nylon anchor strip and 6 tie wraps. Mounting hardware not included.
- Anchor strip may be cut to length required.

Order Part No. 041245

Includes nylon anchor strip and 6 tie wraps

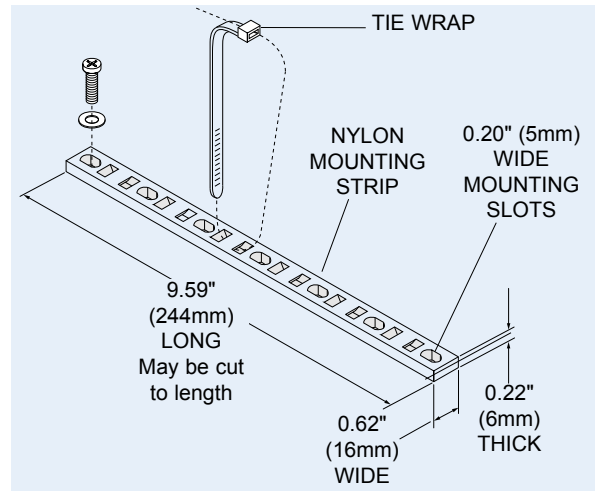
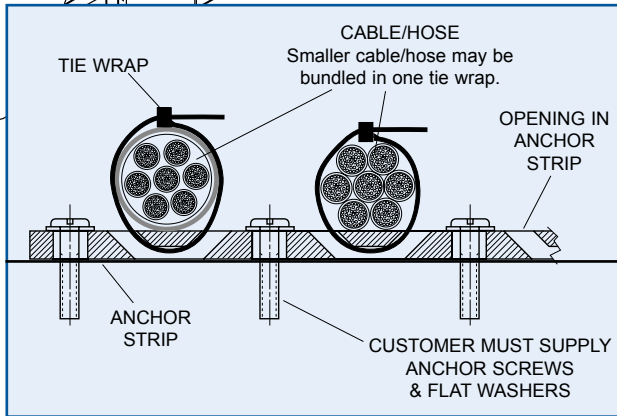

Heavy Duty Cable/hose Tie Bracket

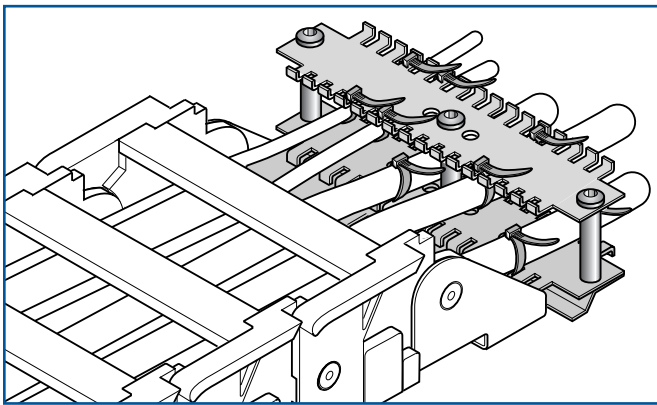

- Affixes hoses or cables at ends of trak to prevent undue wear or stress.
- Dual tie system holds more securely than single ties. Ties not included.
- Rugged baked polyester finished steel with zinc plated hardware.

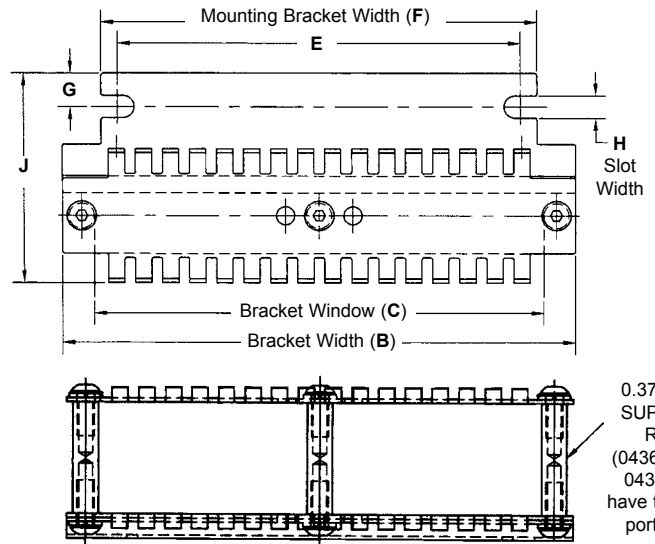
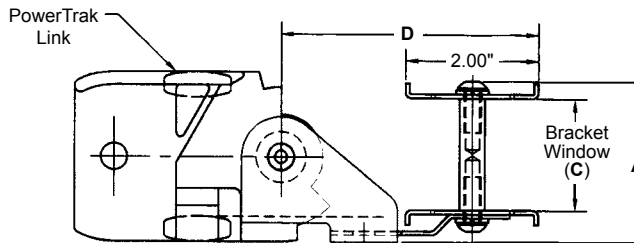

PART NO	CABLE/HOSE MAX. O.D.	A	B	C Ht. x Wd.	D	E	F	G	H	J
04369005	2.12	3.26	9.60	2.50 x 8.66	7.18	6.84 ± 0.68	7.96	0.88	0.438	3.81
04369004	1.46	2.40	7.20	1.65 x 6.26	6.18	5.08 ± 0.62	6.11	0.63	0.406	3.44
04369003	1.46	2.38	7.60	1.65 x 6.66	3.87	5.96 ± 0.16	6.45	0.50	0.344	3.15
04369002	1.46	2.38	5.20	1.65 x 4.26	3.87	3.62 ± 0.16	4.11	0.50	0.344	3.15
04369001	1.46	2.38	3.60	1.65 x 2.66	3.87	1.96 ± 0.16	2.45	0.50	0.344	3.15

All dimensions in inches.

Guide Trays

For extended travels of PowerTrak® GRP and PowerTube™

Guide trays are required when recommended self-supported travel lengths are exceeded (See specification pages for each size). Since the reinforced nylon from which the links are molded is a self-lubricating bearing material, there is no problem if the top portion sags down and slides on the lower portion. In fact, this is a highly desirable condition. But only if the PowerTrak or PowerTube is guided.

The fixed end of the PowerTrak or PowerTube assembly is located at the center of its travel, i.e., the center of the guide tray. When the movable end is pulled past the fixed end and can no longer be supported on itself, it rides on either elevated angles or rollers, depending on model (Figure 1).

For a cable and hose payload exceeding the capacity of the largest model, opposed PowerTrak or PowerTube units can be used dividing the load (Figure 2). In this case, only one support (either a nylon roller or metal shelf) is required and will be positioned between the access slots on the tray wall.

Trays are galvanized steel or optional stainless steel and can be perforated for drainage (optional). Guide trays are available for all sizes except PowerTrak 101P and 101PS.



Standard Tray System

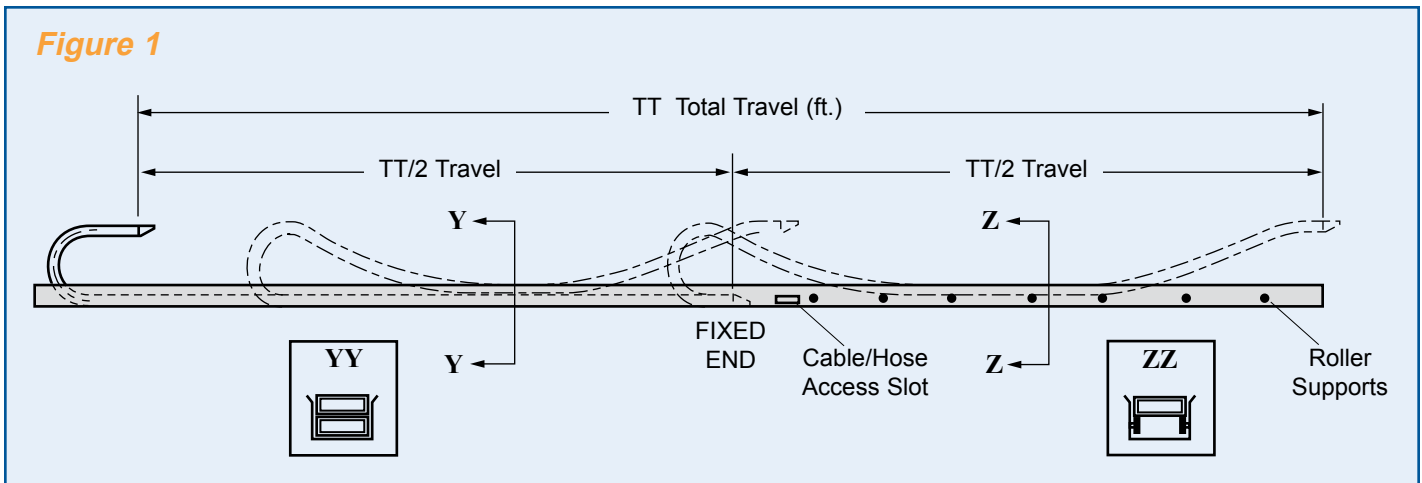

Opposed Tray System

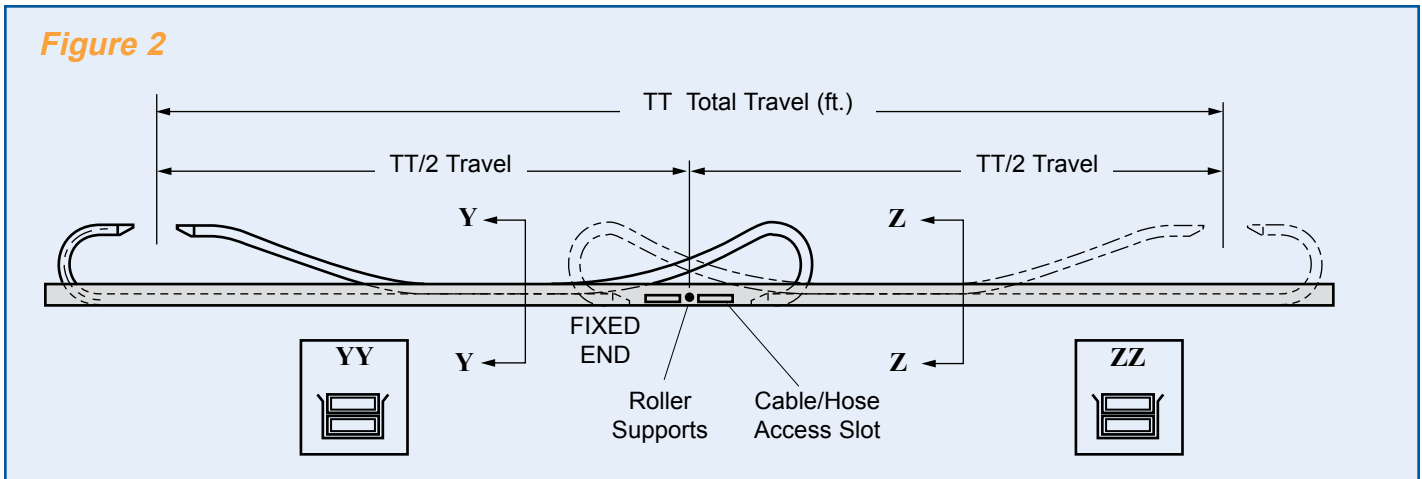

Guide Tray With Angles

PowerTrak® Type 132P †
Type 162P †
PowerTube™ Type 815
Type 1020

Figure 3

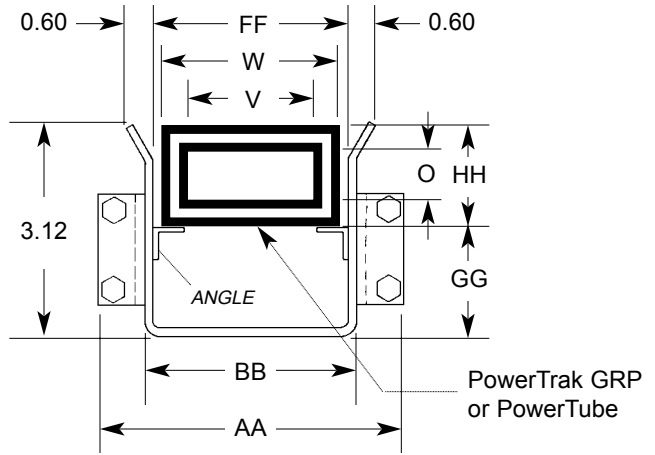

Dimensions in Inches

TYPE	AA†	BB†	V	O	W	FF†	GG	HH	TRAY LENGTH	TRAY LENGTH	TRAY WEIGHT
									FIG. 1	FIG. 2	LBS/FT
132P-I	4.06	2.56	1.50	0.98	2.12	2.32	1.75	1.34	TT + 0.5 ft.	TT + 4.0 ft.	4.4
132P-II	4.86	3.36	2.28	0.98	2.91	3.11	1.75	1.34	TT + 0.5 ft.	TT + 4.0 ft.	4.8
132P-III	5.63	4.13	3.08	0.98	3.70	3.90	1.75	1.34	TT + 0.5 ft.	TT + 4.0 ft.	5.1
162P-I	4.06	2.56	1.50	1.00	2.12	2.32	1.75	1.62	TT + 0.5 ft.	TT + 4.0 ft.	4.4
162P-XI*	4.06	2.56	1.50	1.00	2.12	2.32	1.75	1.62	TT + 0.5 ft.	TT + 4.0 ft.	4.4
162P-II	4.86	3.36	2.28	1.00	2.91	3.11	1.75	1.62	TT + 0.5 ft.	TT + 4.0 ft.	4.8
162P-III	5.63	4.13	3.08	1.00	3.70	3.90	1.75	1.62	TT + 0.5 ft.	TT + 4.0 ft.	5.1
162P-IV	6.61	5.12	4.06	1.00	4.69	4.88	1.75	1.62	TT + 0.5 ft.	TT + 4.0 ft.	5.5
PowerTube 815	4.27	2.78	1.50	0.81	2.04	2.53	1.50	1.38	TT + 0.5 ft.	TT + 4.0 ft.	4.5
PowerTube 1020	4.84	3.34	2.00	1.00	2.60	3.09	1.69	1.56	TT + 0.5 ft.	TT + 4.0 ft.	4.9

† Tray dimensions increase for Type 132P & 162P with RIVETED CONSTRUCTION: Add 0.32" to TRAY WIDTH dimensions AA, BB & FF when using riveted Type 132P & 162P.

* Model 162P-XI is limited to total travel of 50 ft. in a guide tray.

Guide Tray With Rollers

PowerTrak® Type 252P
Type 263P
Type 354P
PowerTube™ Type 1530
Type 2045

Figure 4

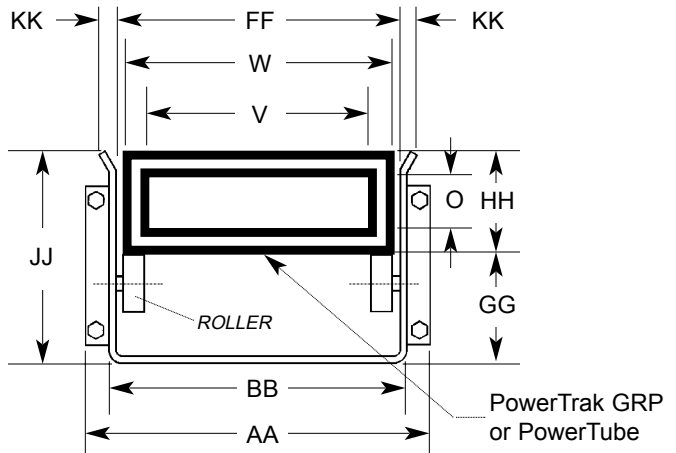

Dimensions in Inches

TYPE	AA†	BB†	V	O	W	FF†	GG	HH	JJ	KK	TRAY LENGTH	TRAY LENGTH	TRAY WEIGHT
											FIG. 1	FIG. 2	LBS/FT
252-P-I	5.70	4.20	2.60	1.75	3.70	3.96	2.63	2.50	4.96	0.82	TT + 1.5 ft.	TT + 6.0 ft.	6.1
252-P-II	7.38	5.86	4.25	1.75	5.36	5.62	2.63	2.50	4.96	0.82	TT + 1.5 ft.	TT + 6.0 ft.	7.0
252-P-III	9.70	8.20	6.60	1.75	7.70	7.96	2.63	2.50	4.96	0.82	TT + 1.5 ft.	TT + 6.0 ft.	7.8
263P	9.58	7.78	6.00	1.88	7.34	7.53	2.78	2.66	5.44	0.80	TT + 2.0 ft.	TT + 6.0 ft.	7.8
354P	11.87	10.05	8.00	2.55	9.65	9.81	3.68	3.56	6.87	0.73	TT + 2.0 ft.	TT + 6.0 ft.	10.0
PowerTube 1530	6.00	4.50	3.00	1.50	3.68	4.26	2.48	2.25	4.85	0.60	TT + 2.0 ft.	TT + 6.0 ft.	5.8
PowerTube 2045	7.62	6.12	4.50	2.00	5.30	5.88	2.98	2.75	5.98	0.60	TT + 2.0 ft.	TT + 6.0 ft.	7.6

Cable & Hose Data

TYPE SO CABLE — 600 VOLT

16 AWG			14 AWG			12 AWG			10 AWG		
No. Cond.	Dia. In.	Weight lb/ft	No. Cond.	Dia. In.	Weight lb/ft	No. Cond.	Dia. In.	Weight lb/ft	No. Cond.	Dia. In.	Weight lb/ft
2	0.374	0.094	2	0.512	0.158	2	0.586	0.204	2	0.638	0.250
3	0.393	0.110	3	0.538	0.184	3	0.616	0.244	3	0.671	0.310
4	0.427	0.144	4	0.584	0.224	4	0.668	0.282	4	0.730	0.371
5	0.510	0.156	5	0.665	0.260	5	0.725	0.322	5	0.796	0.425
6	0.565	0.178	6	0.710	0.302	6	0.805	0.380	6	0.883	0.485
7	0.605	0.202	7	0.710	0.329	7	0.865	0.435	7	0.982	0.593
8	0.645	0.222	8	0.770	0.373	8	0.920	0.475	9	1.127	0.725
9	0.720	0.268	9	0.820	0.414	9	1.020	0.550	10	1.127	0.760
10	0.720	0.278	10	0.885	0.434	10	1.020	0.581	12	1.153	0.850
12	0.740	0.305	12	0.905	0.481	12	1.050	0.645	20	1.455	1.400
14	0.775	0.348	14	1.000	0.556	14	1.105	0.743	24	1.595	1.645
16	0.825	0.386	16	1.050	0.657	16	1.160	0.840	26	1.595	1.740
18	0.860	0.430	18	1.110	0.715	18	1.227	0.925	28	1.725	1.880
20	0.900	0.466	20	1.150	0.785	20	1.287	1.005	32	1.830	2.180
22	0.940	0.503	22	1.210	0.857	22	1.370	1.140	36	1.890	2.400
24	1.015	0.564	24	1.320	0.920	24	1.443	1.225	40	2.030	2.660
26	1.015	0.604	26	1.350	0.986	26	1.443	1.290	44	2.115	2.890
28	1.070	0.654	28	1.370	1.098	28	1.523	1.400	48	2.150	3.100
30	1.070	0.677	30	1.390	1.138	30	1.523	1.450	52	2.200	3.330
32	1.120	0.714	32	1.450	1.220	40	1.820	1.990	56	2.275	3.550
34	1.155	0.807	34	1.495	1.300	44	1.900	2.140			
36	1.155	0.820	36	1.515	1.359	48	1.930	2.300			
40	1.235	0.881	40	1.550	1.429	52	1.980	2.450			
44	1.280	0.940	44	1.715	1.619	56	2.020	2.600			
48	1.290	0.995	48	1.740	1.734	60	2.090	2.780			
52	1.360	1.100	52	1.784	1.843						
56	1.410	1.170	56	1.865	2.030						
60	1.465	1.260	60	1.925	2.156						

TYPE W CABLE — 600 VOLT

AWG Size	No. Cond.	Dia. In.	Weight lb/ft
8	2	0.788	0.328
	3	0.894	0.470
	4	0.966	0.583
6	2	0.872	0.425
	3	0.983	0.614
	4	1.068	0.769
4	2	1.040	0.780
	3	1.068	0.797
	4	1.166	1.019
3	2	1.033	0.687
	3	1.135	0.950
	4	1.241	1.197
2	2	1.177	0.888
	3	1.244	1.152
	4	1.326	1.429
1	2	1.365	1.090
	3	1.413	1.491
	4	1.548	1.877
1/0	2	1.454	1.386
	3	1.539	1.805
	4	1.686	2.309
2/0	2	1.555	1.640
	3	1.647	2.154
	4	1.807	2.738

TYPE G-GC CABLE — 600 VOLT

AWG Size	No. Cond.	Dia. In.	Weight lb/ft
8	3	0.915	0.661
6	3	1.000	0.792
4	3	1.120	1.088
3	3	1.180	1.250
2	3	1.250	1.436
1	3	1.440	1.856
1/0	3	1.565	2.270
2/0	3	1.630	2.660

Refer to the National Electric Code for ampere ratings and other details.

HOSE GENERAL PURPOSE

Listings for general purpose hose do NOT include fluid weight. Specific fluid weights should be added when figuring Total Cable/Hose Weight.

I.D. In.	Braid	O.D. In.	PSI (WORKING)	Weight lb/ft
.25	2	0.59	250	0.13
.38	2	0.72	250	0.18
.50	2	0.84	250	0.23
.75	2	1.16	250	0.37
1.00	2	1.50	150	0.64
1.25	2	1.75	150	1.01
1.50	2	2.00	150	1.06

HOSE SINGLE HYDRAULIC

Listings for single hydraulic hose do NOT include fluid weight. Specific fluid weights should be added when figuring Total Cable/Hose Weight.

I.D. In.	Braid	O.D. In.	PSI (WORKING)	Weight lb/ft
.25	2	0.58	5000	0.23
.38	2	0.73	4000	0.35
.50	2	0.86	3500	0.42
.75	2	1.14	2250	0.60
1.00	2	1.48	2000	0.89
1.25	2	1.87	1625	1.40

Whenever possible, refer to specific manufacturer's information regarding cable or hose. If this information is not available, these charts are composites and may be used as guides to typical cable and hose size and weights.

Cable Management

Since 1911 Gleason Reel Corp. has been in the business of CABLE MANAGEMENT. Our products are designed to convey and protect valuable cables and hoses that power and control moving machines of all types. They improve productivity and safety on the job by moving cables and hoses away from hazardous locations on machinery or the shop floor into a controlled environment. Whether you choose Reels for efficient storage and payout from virtually any angle, Festoon Systems for overhead applications or PowerTrak® for protection on machinery in motion, your cables and/or hoses will last longer and provide better service with a cable management system from **Gleason Reel Corp.** ...

...The Cable & Hose Management Company!



In addition to three types of PowerTrak, one of which is detailed in this catalog, Gleason manufactures a complete line of motor or spring driven and hand operated cable and hose reels in a wide variety of sizes as well as I-beam, c-rail and wire rope supported festoon systems for handling cables or hoses overhead. Contact Gleason Reel Corp. or your local Gleason Representative.



Gleason Reel Corp.

P.O. Box 26 • 600 South Clark St.
Mayville, Wisconsin 53050-0026
Phone 920-387-4120 • FAX 920-387-4189
www.hubbell-gleason.com