

Hose-Master

Dimensional Guide

All dimensions in inches. For millimeters, multiply inches by 25.4.

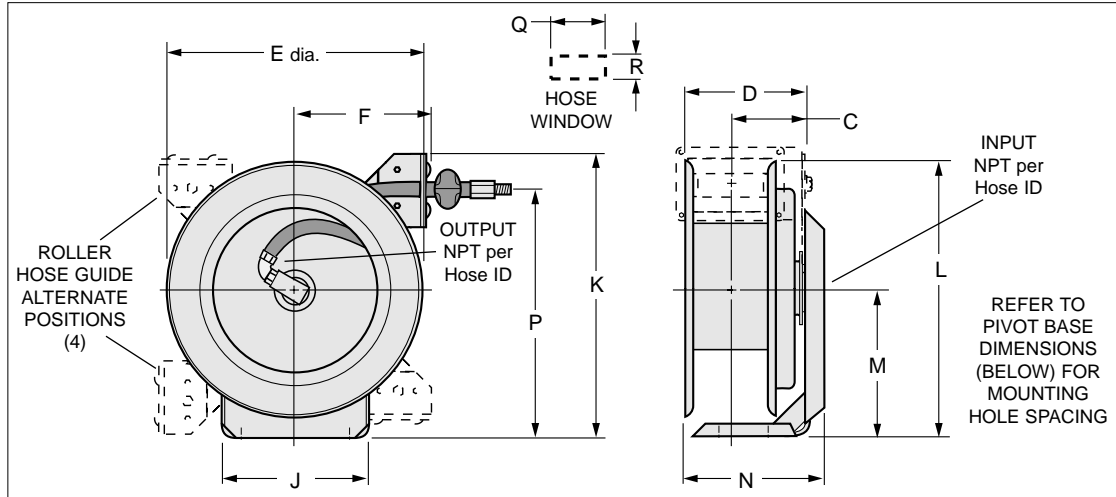

NOMINAL SPOOL DIAMETER	C	D	E	F	J	K	L	M	N	P	Q	R
14	3.88	5.75	13.75	8.25	8.00	16.25	15.00	8.12	7.00	14.25	2.50	1.25
19	5.81	8.19	19.00	10.00	11.00	20.50	20.25	10.75	9.50	18.50	3.50	1.25

Average Net Weight Less Hose

MODEL	WEIGHT
HM 141	30 lbs.
HM 142	32 lbs.
HM 143	42 lbs.
HM 194	75 lbs.
HM 195	58 lbs.
HM 197	60 lbs.

#SB14 340° Pivot Base

(OPTIONAL)

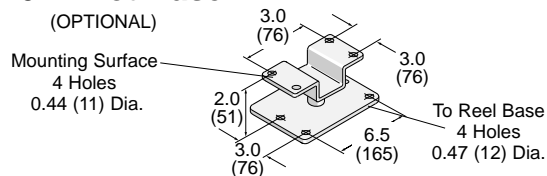

#SB19 340° Pivot Base

(OPTIONAL)

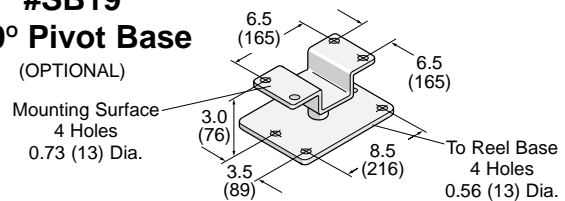

NOTE: Pivot Bases shown with reel mounting plate facing down, position used when reel is hung overhead.

Neoprene Ball Stop (OPTIONAL)

MODEL NUMBER	Hose Range (O.D. min/max)
C0	0.25 – 0.44
C1	0.47 – 0.56
C2	0.57 – 0.69
C3	0.70 – 0.88

