

Typical I-Beam Festoon System

GENERAL LAYOUT • DEFINITIONS • DESCRIPTIONS • TERMS • SYMBOLS

SYSTEM IN STORED POSITION Flat cable shown. Round cable/hose similar.

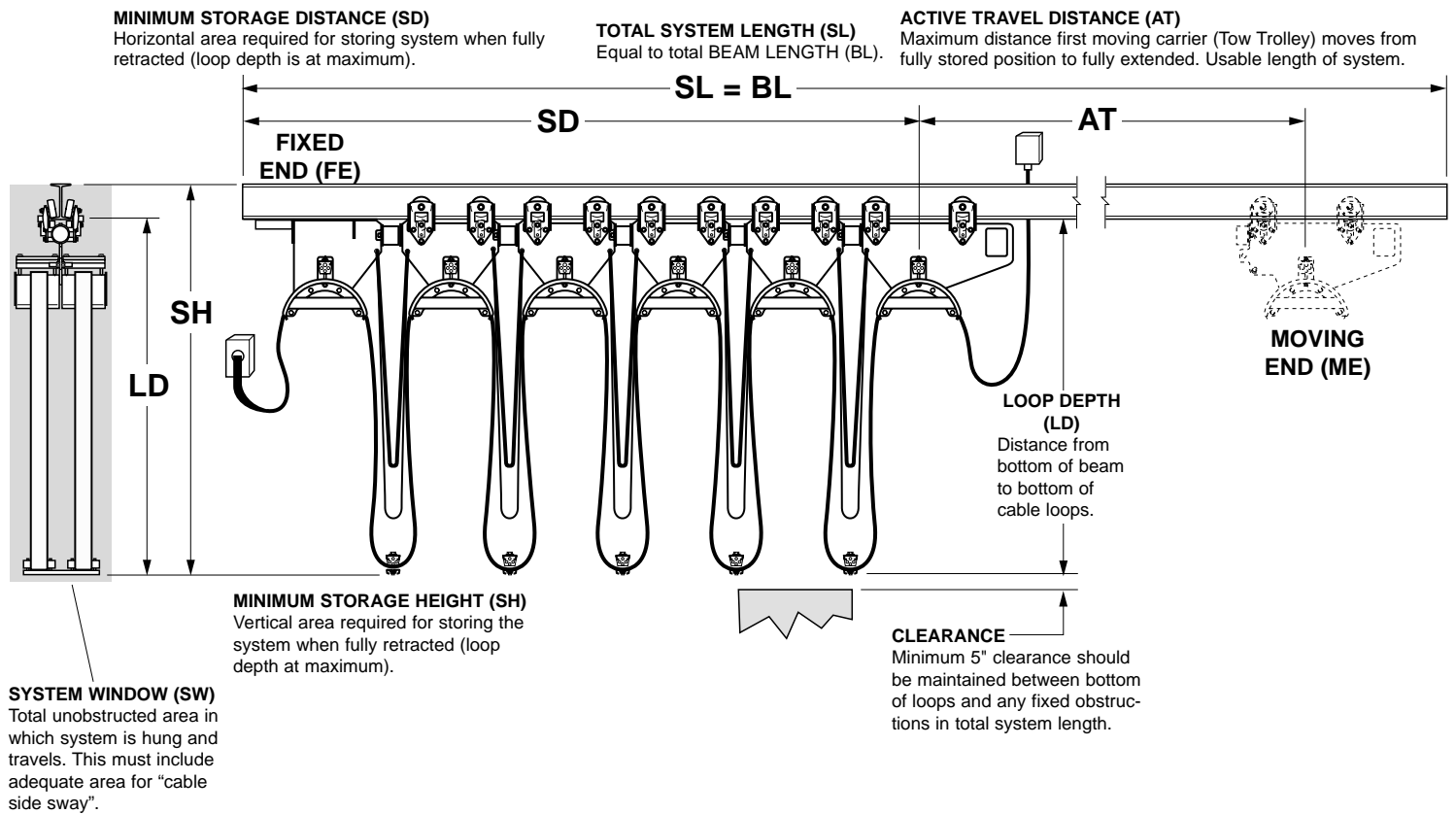

SYSTEM IN EXTENDED POSITION Flat cable shown. Round cable/hose similar.

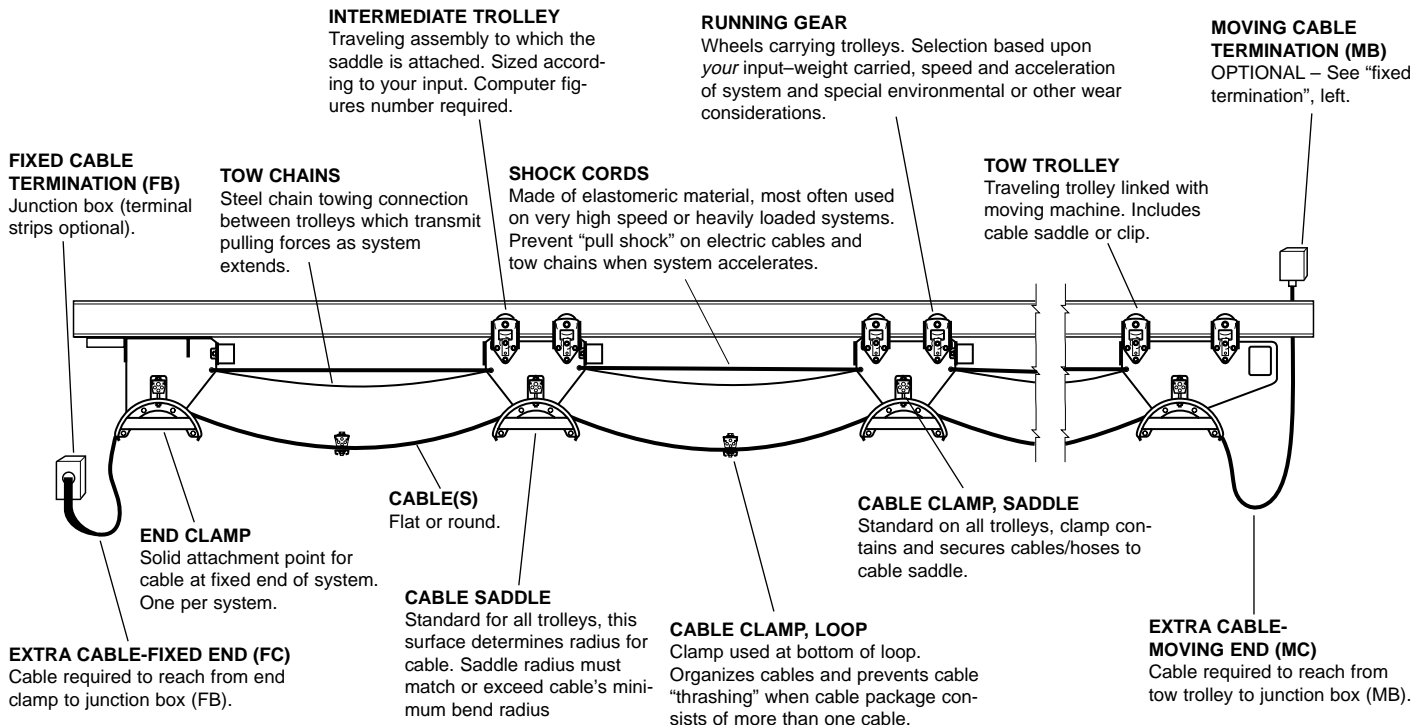

Beam•Master™ ...Extra Durable

Heavy duty components and high quality finishes make Gleason Beam•Master Festoon Systems rugged, smooth running and long lasting.

TYPICAL BEAM•MASTER TROLLEY (I-130 shown)

Running Gear

Either crowned (shown) or flanged.
Steel standard. Nylon available.

Trolley Body

Standard finish is baked on orange polyester powder coating.

Saddle

For flat cable or mixed bundle. Standard finish is baked on orange polyester powder coating.

HEAVY DUTY BUMPERS

Absorb impacts caused by trolleys "packing together" on stored end of system.

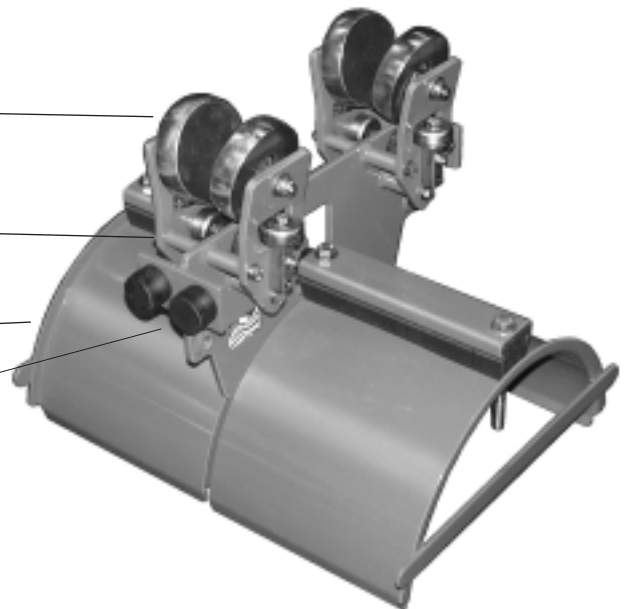

Cable & Saddle Guidelines

1. Bending Cable (All saddles and clips)

For good service and long life, it is best to follow the rule: "BIG BENDS ARE BEST". Cable producers vary in applying a multiplier. Gleason uses the chart below.

CABLE O.D..	MIN. RADIUS	MIN. SADDLE DIA.
Under 0.3 in.	3 x O.D	6 x O.D.
Under 0.5 in.	4 x O.D	8 x O.D.
Above 0.5 in.	5 x O.D	10 x O.D.



2. Cable O.D. Variations (Type M saddles)

Variations in cable size (O.D.) should be kept to a minimum. Clamping is most effective when all cables/hoses are the same O.D. or close as in figure 1. This ensures secure clamping. Wide variation in O.D. (Fig. 2) makes clamping difficult and cable/hose may not remain secure on the saddle.



FIG. 1 BEST!



FIG. 2 poor!

3. Balance in Loading Cable (Type M saddles)

This is important for smooth running, long bearing life and component alignment. Distribute the load evenly, with the heaviest cables nearest the centerline.



FIG. 3 BEST!



FIG. 4 poor!

4. Flat Cable Stacking (Type F saddles)

a) Secure Clamping

EXTREMELY IMPORTANT: At least 50% of the cable surface must be under clamp pressure.

b) Height Consideration

Flat cable stacking is best when width is 3 or 4 times height (Fig. 5 & 6, above). High stacking can work as long as equal pressure is applied to all cables (Fig. 8).

c) Configuration

BIG CABLE ON TOP (Fig. 9) provides maximum bending radius for largest cables, improves heat dissipation for power cables and transfers pulling force to largest cables when tow chains are not used.

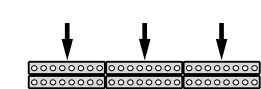

FIG. 5 BEST!
100% Clamping

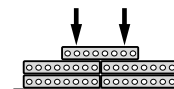

FIG. 6 good!
50% Clamping

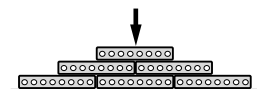

FIG. 7 poor!

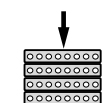

FIG. 8
Unstable, but OK.

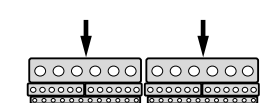

FIG. 9