

# GLEASON Beam•Master™ SERIES I162

## SINGLE or DUAL Clamp, Clips

- FLAT, ROUND OR MIXED CABLE/HOSE
- CROWNED 6" DIA. STEEL WHEELS STANDARD
- ANTI-LIFT & SIDE GUIDE ROLLERS STANDARD
- SEALED BALL BEARINGS STANDARD

- MAX SADDLE DIAMETER = 18.12"
- MAX TROLLEY LOAD = 1100 lbs.
- TRAVEL SPEEDS TO 800 fpm
- ACCELERATION—Consult us if over 2.0 ft/sec<sup>2</sup>.
- TRAVEL LENGTHS UNLIMITED

### Standard Trolley Design

- Crowned 6" steel wheels with side guide rollers.
- Anti-lift rollers
- Sealed bearings are pre-lubricated for life
- Tow trolley included as standard
- Zinc plated hardware
- Orange baked polyester powder finish
- Heavy duty bumpers
- Typical mounting on S6 or larger beams (S5 or larger with optional flanged wheels)— contact us for special situations
- Cable clamp allows cable pkg height to vary up to 0.63"

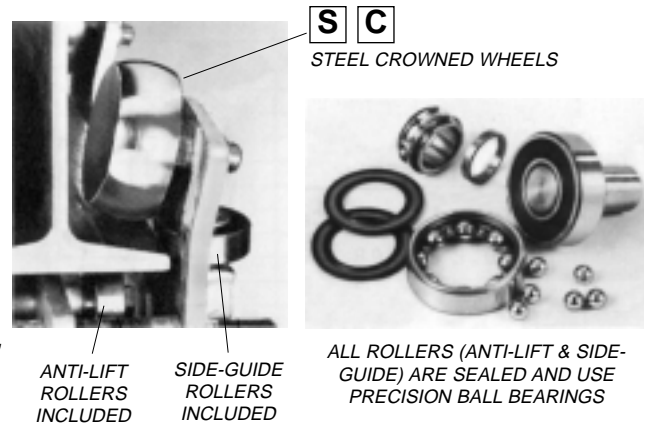

### Model Number Explained

For STANDARD DESIGN, specific model numbers are on the following page.

Standard Intermediate Trolley*							Standard	Std. Wheels***	Your Beam		
TYPE	CLAMP STYLE	SADDLE DIAMETER	WINDOW HEIGHT	WINDOW WIDTH	ITEM	FINISH	WHEEL MAT'L	WHEEL STYLE	WHEEL LUBE		
#I162	D**	10	- 33	07	I	- ZP -	S	C	P -	<input type="checkbox"/> <input type="checkbox"/> <input type="checkbox"/> x <input type="checkbox"/> <input type="checkbox"/> <input type="checkbox"/>	
Chosen by computer						Options you select	ZINC HARDWARE PAINTED TROLLEY	STEEL CROWNED	PRE-LUB	Minimum Beam Height = 8.0"	
* Example above is for INTERMEDIATE TROLLEY (I) Use same option changes (at right) for other components as required.						Options	Wheel Options				
** Clamp may be dual (D) or single (S) depending on saddle width. If clips (C) are desired, consult factory for more details.						<b>S</b> STAINLESS	<b>G</b> GALVANIZED	<b>N</b> NYLON	<b>F</b> FLANGED	<b>G</b> REGREASE	
*** Not applicable to end clamps											

### Optional Design Features

CODE	OPTION
<b>F</b>	FLANGED (STEEL ONLY) WHEELS WITH ANTI-LIFT ROLLERS
<b>N</b>	CROWNED NYLON WHEELS WITH SIDE GUIDE ROLLERS
<b>G</b>	RE-GREASABLE BEARINGS ON MAIN WHEELS
<b>S</b>	STAINLESS STEEL HARDWARE
<input type="checkbox"/>	OTHER FINISHES AVAILABLE – PLEASE CONTACT US
<input type="checkbox"/>	PRE-ASSEMBLY ON SHIPPING FRAME AVAILABLE

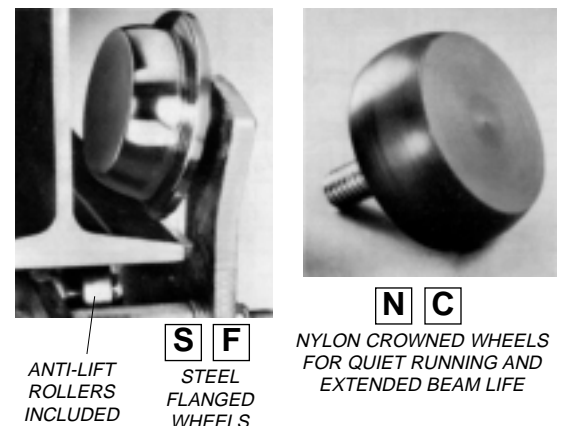

### Accessories See detail pages at back of catalog

- CABLE CLAMPS
- SHOCK CORDS
- CABLE, ROUND OR FLAT; HOSE
- TERMINAL BOX(ES)
- TY-RAPS
- CABLE GLANDS FOR SINGLE CABLES OR GROUPS
- TOW ROPES
- TERMINAL BLOCKS

# Series I162 Components & Dimensions

**SINGLE & DUAL Clamp Design**—Contact us for multiple tier requirements. Also available with cable/hose clips.

All dimensions in inches unless otherwise specified.

## End Clamp *One Required*

Model Number <i>w/ Std Hardware &amp; Wheels</i>	Saddle Dia. D	Window Height P	Window Width* V	Overall Length L	Overall Width W	Below Beam H	Saddle Locator M	Bolt K
<b>I162-S10-1004E-ZP</b>	10.25	1.06	4.38	12.32	11.51	15.10	8.52	7.07
<b>I162-S10-1006E-ZP</b>	10.25	1.06	6.19	12.32	15.13	15.10	8.52	7.07
<b>I162-D10-1007E-ZP</b>	10.25	1.06	7.88	12.32	20.51	15.10	8.52	7.07
<b>I162-D10-1010E-ZP</b>	10.25	1.06	10.17	12.32	25.06	15.10	8.52	7.07
<b>I162-D10-1012E-ZP</b>	10.25	1.06	12.69	12.32	30.20	15.10	8.52	7.07
<b>I162-S10-3304E-ZP</b>	10.25	3.30	4.38	15.50	11.51	15.10	10.51	10.25
<b>I162-S10-3306E-ZP</b>	10.25	3.30	6.19	15.50	15.13	15.10	10.51	10.25
<b>I162-D10-3307E-ZP</b>	10.25	3.30	7.88	15.50	20.51	15.10	10.51	10.25
<b>I162-D10-3310E-ZP</b>	10.25	3.30	10.17	15.50	25.06	15.10	10.51	10.25
<b>I162-D10-3312E-ZP</b>	10.25	3.30	12.69	15.50	30.20	15.10	10.51	10.25
<b>I162-S14-1404E-ZP</b>	14.12	1.44	4.38	15.50	11.51	16.60	10.51	10.25
<b>I162-S14-1406E-ZP</b>	14.12	1.44	6.19	15.50	15.13	16.60	10.51	10.25
<b>I162-D14-1407E-ZP</b>	14.12	1.44	7.88	15.50	20.51	16.60	10.51	10.25
<b>I162-D14-1410E-ZP</b>	14.12	1.44	10.17	15.50	25.06	16.60	10.51	10.25
<b>I162-D14-1412E-ZP</b>	14.12	1.44	12.69	15.50	30.20	16.60	10.51	10.25
<b>I162-S18-1804E-ZP</b>	18.12	1.81	4.38	19.00	11.51	18.10	12.65	13.76
<b>I162-S18-1806E-ZP</b>	18.12	1.81	6.19	19.00	15.13	18.10	12.65	13.76
<b>I162-D18-1807E-ZP</b>	18.12	1.81	7.88	19.00	20.51	18.10	12.65	13.76
<b>I162-D18-1810E-ZP</b>	18.12	1.81	10.17	19.00	25.06	18.10	12.65	13.76
<b>I162-D18-1812E-ZP</b>	18.12	1.81	12.69	19.00	30.20	18.10	12.65	13.76

Fits all beam sizes.

\* Window width each side of frame plate on single clamp models (designated by "S" in model number) or distance between clamp bolts on double clamp models ("D" in number). Window height and width do not apply to clip models. Clips available on all saddle widths. Consult factory for quantity and size of clips for your application. To order clips, replace "S" or "D" in model number with "C".

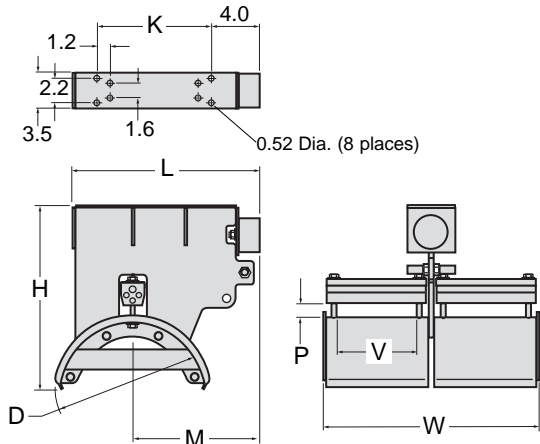

## Intermediate Trolley *Quantity as Required*

Model Number <i>w/ Std Hardware &amp; Wheels</i>	Saddle Dia. D	Window Height P	Window Width* V	Overall Length L	Overall Width W	Below Beam H	Saddle Locator M
<b>I162-S10-1004I-ZP-SCP-□</b>	10.25	1.06	4.38	15.36	11.51	15.10	7.68
<b>I162-S10-1006I-ZP-SCP-□</b>	10.25	1.06	6.19	15.36	15.13	15.10	7.68
<b>I162-D10-1007I-ZP-SCP-□</b>	10.25	1.06	7.88	15.36	20.51	15.10	7.68
<b>I162-D10-1010I-ZP-SCP-□</b>	10.25	1.06	10.17	15.36	25.06	15.10	7.68
<b>I162-D10-1012I-ZP-SCP-□</b>	10.25	1.06	12.69	15.36	30.20	15.10	7.68
<b>I162-S10-3304I-ZP-SCP-□</b>	10.25	3.30	4.38	18.62	11.51	15.10	9.31
<b>I162-S10-3306I-ZP-SCP-□</b>	10.25	3.30	6.19	18.62	15.13	15.10	9.31
<b>I162-D10-3307I-ZP-SCP-□</b>	10.25	3.30	7.88	18.62	20.51	15.10	9.31
<b>I162-D10-3310I-ZP-SCP-□</b>	10.25	3.30	10.17	18.62	25.06	15.10	9.31
<b>I162-D10-3312I-ZP-SCP-□</b>	10.25	3.30	12.69	18.62	30.20	15.10	9.31
<b>I162-S14-1404I-ZP-SCP-□</b>	14.12	1.44	4.38	18.62	11.51	16.60	9.31
<b>I162-S14-1406I-ZP-SCP-□</b>	14.12	1.44	6.19	18.62	15.13	16.60	9.31
<b>I162-D14-1407I-ZP-SCP-□</b>	14.12	1.44	7.88	18.62	20.51	16.60	9.31
<b>I162-D14-1410I-ZP-SCP-□</b>	14.12	1.44	10.17	18.62	25.06	16.60	9.31
<b>I162-D14-1412I-ZP-SCP-□</b>	14.12	1.44	12.69	18.62	30.20	16.60	9.31
<b>I162-S18-1804I-ZP-SCP-□</b>	18.12	1.81	4.38	22.94	11.51	18.10	11.47
<b>I162-S18-1806I-ZP-SCP-□</b>	18.12	1.81	6.19	22.94	15.13	18.10	11.47
<b>I162-D18-1807I-ZP-SCP-□</b>	18.12	1.81	7.88	22.94	20.51	18.10	11.47
<b>I162-D18-1810I-ZP-SCP-□</b>	18.12	1.81	10.17	22.94	25.06	18.10	11.47
<b>I162-D18-1812I-ZP-SCP-□</b>	18.12	1.81	12.69	22.94	30.20	18.10	11.47

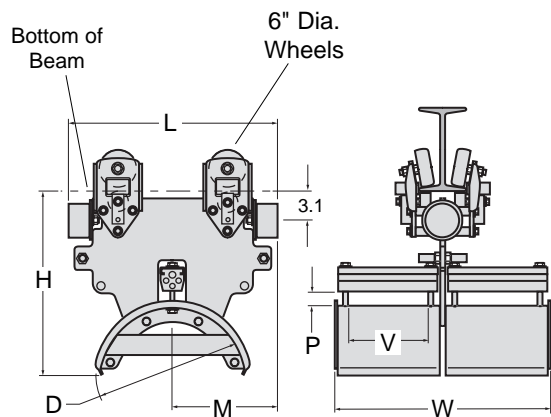

Your beam size must be added to complete model number. See previous pages.

\* Window width each side of frame plate on single clamp models (designated by "S" in model number) or distance between clamp bolts on double clamp models ("D" in number). Window height and width do not apply to clip models. Clips available on all saddle widths. Consult factory for quantity and size of clips for your application. To order clips, replace "S" or "D" in model number with "C".

# Series I162 Components & Dimensions, con't.

SINGLE & DUAL Clamp Design—Contact us for multiple tier requirements. Also available with cable/hose clips.

All dimensions in inches unless otherwise specified.

## Tow Trolley *Standard...One Required*

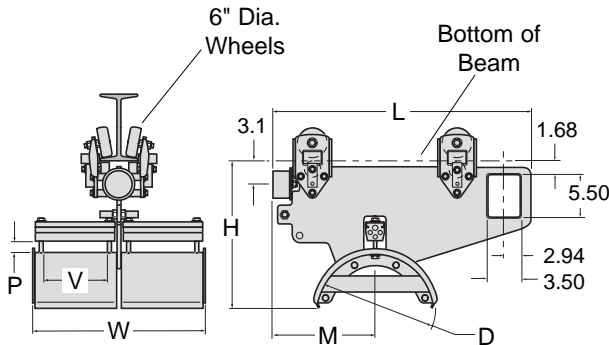

Model Number w/ Std Hardware & Wheels	Saddle Dia. D	Window Height P	Window Width* V	Overall Length L	Overall Width W	Below Beam H	Saddle Locator M
I162-S10-1004T-ZP-SCP-□	10.25	1.06	4.38	18.66	11.51	15.10	7.76
I162-S10-1006T-ZP-SCP-□	10.25	1.06	6.19	18.66	15.13	15.10	7.76
I162-D10-1007T-ZP-SCP-□	10.25	1.06	7.88	18.66	20.51	15.10	7.76
I162-D10-1010T-ZP-SCP-□	10.25	1.06	10.17	18.66	25.06	15.10	7.76
I162-D10-1012T-ZP-SCP-□	10.25	1.06	12.69	18.66	30.20	15.10	7.76
I162-S10-3304T-ZP-SCP-□	10.25	3.30	4.38	25.31	11.51	15.10	11.00
I162-S10-3306T-ZP-SCP-□	10.25	3.30	6.19	25.31	15.13	15.10	11.00
I162-D10-3307T-ZP-SCP-□	10.25	3.30	7.88	25.31	20.51	15.10	11.00
I162-D10-3310T-ZP-SCP-□	10.25	3.30	10.17	25.31	25.06	15.10	11.00
I162-D10-3312T-ZP-SCP-□	10.25	3.30	12.69	25.31	30.20	15.10	11.00
I162-S14-1404T-ZP-SCP-□	14.12	1.44	4.38	25.31	11.51	16.60	11.00
I162-S14-1406T-ZP-SCP-□	14.12	1.44	6.19	25.31	15.13	16.60	11.00
I162-D14-1407T-ZP-SCP-□	14.12	1.44	7.88	25.31	20.51	16.60	11.00
I162-D14-1410T-ZP-SCP-□	14.12	1.44	10.17	25.31	25.06	16.60	11.00
I162-D14-1412T-ZP-SCP-□	14.12	1.44	12.69	25.31	30.20	16.60	11.00
I162-S18-1804T-ZP-SCP-□	18.12	1.81	4.38	30.82	11.51	18.10	13.75
I162-S18-1806T-ZP-SCP-□	18.12	1.81	6.19	30.82	15.13	18.10	13.75
I162-D18-1807T-ZP-SCP-□	18.12	1.81	7.88	30.82	20.51	18.10	13.75
I162-D18-1810T-ZP-SCP-□	18.12	1.81	10.17	30.82	25.06	18.10	13.75
I162-D18-1812T-ZP-SCP-□	18.12	1.81	12.69	30.82	30.20	18.10	13.75

Your beam size must be added to complete model number. See previous pages.

\* Window width each side of frame plate on single clamp models (designated by "S" in model number) or distance between clamp bolts on double clamp models ("D" in number). Window height and width do not apply to clip models. Clips available on all saddle widths. Consult factory for quantity and size of clips for your application. To order clips, replace "S" or "D" in model number with "C".

## Tow Clamp *Optional...Replaces Tow Trolley (one required)*

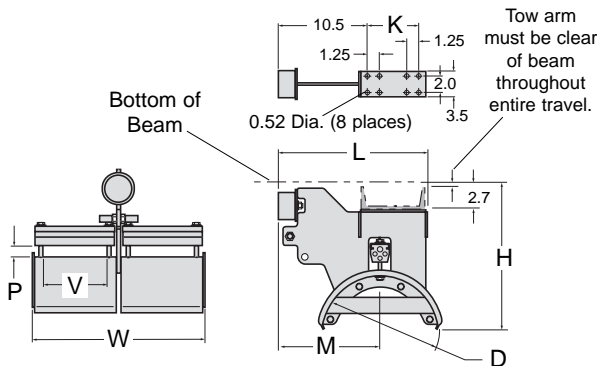

Model Number w/ Std Hardware & Wheels	Saddle Dia. D	Window Height P	Window Width* V	Overall Length L	Overall Width W	Below Beam H	Saddle Locator M	Bolt K
I162-S10-1004C-ZP	10.25	1.06	4.38	15.50	11.51	15.10	12.03	5.00
I162-S10-1006C-ZP	10.25	1.06	6.19	15.50	15.13	15.10	12.03	5.00
I162-D10-1007C-ZP	10.25	1.06	7.88	15.50	20.51	15.10	12.03	5.00
I162-D10-1010C-ZP	10.25	1.06	10.17	15.50	25.06	15.10	12.03	5.00
I162-D10-1012C-ZP	10.25	1.06	12.69	15.50	30.20	15.10	12.03	5.00
I162-S10-3304C-ZP	10.25	3.30	4.38	15.50	11.51	15.10	12.03	5.00
I162-S10-3306C-ZP	10.25	3.30	6.19	15.50	15.13	15.10	12.03	5.00
I162-D10-3307C-ZP	10.25	3.30	7.88	15.50	20.51	15.10	12.03	5.00
I162-D10-3310C-ZP	10.25	3.30	10.17	15.50	25.06	15.10	12.03	5.00
I162-D10-3312C-ZP	10.25	3.30	12.69	15.50	30.20	15.10	12.03	5.00
I162-S14-1404C-ZP	14.12	1.44	4.38	15.50	11.51	16.60	12.03	5.00
I162-S14-1406C-ZP	14.12	1.44	6.19	15.50	15.13	16.60	12.03	5.00
I162-D14-1407C-ZP	14.12	1.44	7.88	15.50	20.51	16.60	12.03	5.00
I162-D14-1410C-ZP	14.12	1.44	10.17	15.50	25.06	16.60	12.03	5.00
I162-D14-1412C-ZP	14.12	1.44	12.69	15.50	30.20	16.60	12.03	5.00
I162-S18-1804C-ZP	18.12	1.81	4.38	19.00	11.51	18.10	19.00	7.00
I162-S18-1806C-ZP	18.12	1.81	6.19	19.00	15.13	18.10	19.00	7.00
I162-D18-1807C-ZP	18.12	1.81	7.88	19.00	20.51	18.10	19.00	7.00
I162-D18-1810C-ZP	18.12	1.81	10.17	19.00	25.06	18.10	19.00	7.00
I162-D18-1812C-ZP	18.12	1.81	12.69	19.00	30.20	18.10	19.00	7.00

Fits all beam sizes.

\* Window width each side of frame plate on single clamp models (designated by "S" in model number) or distance between clamp bolts on double clamp models ("D" in number). Window height and width do not apply to clip models. Clips available on all saddle widths. Consult factory for quantity and size of clips for your application. To order clips, replace "S" or "D" in model number with "C".