

GLEASON Beam • Master™ SERIES I130-D

DUAL Clamp

- FLAT, ROUND OR MIXED CABLE/HOSE
- CROWNED 4" DIA. STEEL WHEELS STANDARD
- ANTI-LIFT & SIDE GUIDE ROLLERS STANDARD
- SEALED BALL BEARINGS STANDARD

- MAX SADDLE DIAMETER = 18.12"
- MAX TROLLEY LOAD = 700 lbs.
- TRAVEL SPEEDS TO 650 fpm
- ACCELERATION—Consult us if over 2.0 ft/sec².
- TRAVEL LENGTHS UNLIMITED

Standard Trolley Design

- Crowned 4" steel wheels with side guide rollers.
- Anti-lift rollers
- Sealed bearings are pre-lubricated for life
- Tow trolley included as standard
- Zinc plated hardware
- Orange baked polyester powder finish
- Heavy duty bumpers
- Typical mounting on S5 or larger beams – contact us for special situations
- Cable clamp allows cable pkg height to vary up to 0.63"

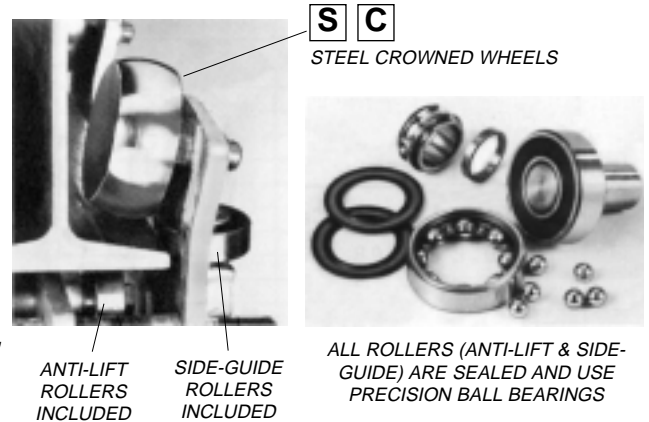

Model Number Explained

For STANDARD DESIGN, specific model numbers are on the following page.

Standard Intermediate Trolley*							Std. Hdwr.	Std. Wheels**	Your Beam**	
TYPE	CLAMP STYLE	SADDLE DIAMETER	WINDOW HEIGHT	WINDOW WIDTH	ITEM	HARDWARE MATERIAL	WHEEL MAT'L	WHEEL STYLE	WHEEL LUBE	
#I130	D	10	- 33	07	I	Z	S	C	P	<input type="checkbox"/> <input type="checkbox"/> <input type="checkbox"/> x <input type="checkbox"/> <input type="checkbox"/> <input type="checkbox"/>
Chosen by computer						Hdwr Option	Wheel Options			Minimum Beam Height = 5.0"
Options You select						S STAINLESS	N NYLON	F FLANGED	G REGREASE	**Not applicable to end clamps
* Example above is for INTERMEDIATE TROLLEY (I) Use same option changes (at right) for other components as required.										

Optional Design Features

CODE	OPTION
F	FLANGED (STEEL ONLY) WHEELS WITH ANTI-LIFT ROLLERS
N	CROWNED NYLON WHEELS WITH SIDE GUIDE ROLLERS
G	RE-GREASABLE BEARINGS ON MAIN WHEELS
S	STAINLESS STEEL HARDWARE
<input type="checkbox"/>	OTHER FINISHES AVAILABLE – PLEASE CONTACT US
<input type="checkbox"/>	PRE-ASSEMBLY ON SHIPPING FRAME AVAILABLE

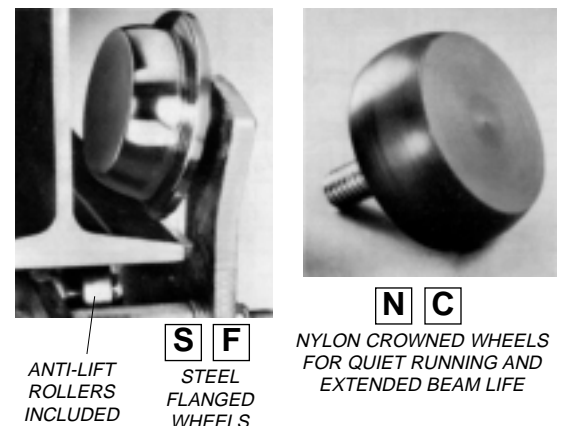

Accessories

See detail pages at back of catalog

- CABLE CLAMPS
- SHOCK CORDS
- CABLE, ROUND OR FLAT; HOSE
- TERMINAL BOX(ES)
- TY-RAPS
- CABLE GLANDS FOR SINGLE CABLES OR GROUPS
- TOW ROPES
- TERMINAL BLOCKS

Series I130-D Components & Dimensions

For MIXED Cable or Hose

All dimensions in inches unless otherwise specified.

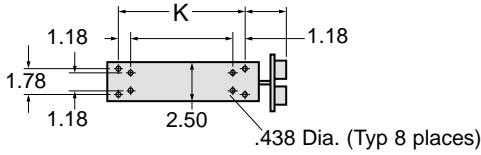

End Clamp *One Required*

Model Number w/ Std Hardware	Saddle Radius R	Saddle Dia. D	Window Height P	Window Width* V	Overall Length L	Overall Width W	Below Beam H	Saddle Locator M	Mtg. Locator J	Bolts K
I130-D10-3307E-Z	5.13	10.25	3.38	7.88	12.75	20.44	13.22	9.31	4.81	6.69
I130-D14-1407E-Z	7.06	14.12	1.44	7.88	15.31	20.44	13.22	10.72	3.44	10.63
I130-D14-1412E-Z	7.06	14.12	1.44	12.69	15.31	30.06	13.22	10.72	3.44	10.63
I130-D18-1807E-Z	9.06	18.12	1.81	7.88	18.63	20.44	16.09	13.47	3.19	14.19
I130-D18-1812E-Z	9.06	18.12	1.81	12.69	18.63	30.06	16.09	13.47	3.19	14.19

Fits all beam sizes. * Window width each side.

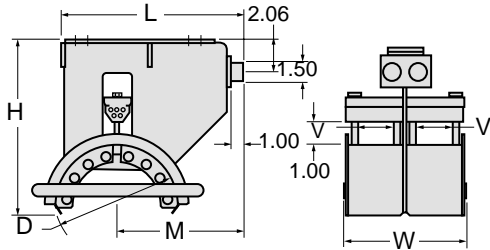

Intermediate Trolley *Quantity as Required*

Model Number w/ Std Hardware & Wheels	Saddle Radius R	Saddle Dia. D	Window Height P	Window Width* V	Overall Length L	Overall Width W	Below Beam H	Saddle Locator M
I130-D10-3307I-Z-SCP-□	5.13	10.25	3.38	7.88	17.88	20.44	13.07	8.94
I130-D14-1407I-Z-SCP-□	7.06	14.12	1.44	7.88	17.88	20.44	13.07	8.94
I130-D14-1412I-Z-SCP-□	7.06	14.12	1.44	12.69	17.88	30.06	13.07	8.94
I130-D18-1807I-Z-SCP-□	9.06	18.12	1.81	7.88	22.59	20.44	15.94	11.29
I130-D18-1812I-Z-SCP-□	9.06	18.12	1.81	12.69	22.59	30.06	15.94	11.29

Your beam size must be added to complete model number. See previous pages.

* Window width each side.

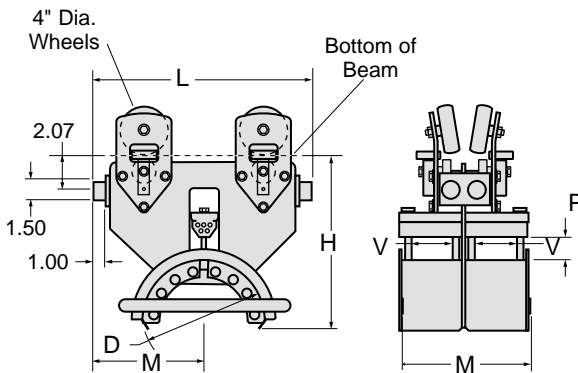

Tow Trolley *Standard...One Required*

Model Number w/ Std Hardware & Wheels	Saddle Radius R	Saddle Dia. D	Window Height P	Window Width* V	Overall Length L	Overall Width W	Below Beam H	Saddle Locator M
I130-D10-3307T-Z-SCP-□	5.13	10.25	3.38	7.88	20.19	20.44	13.07	8.94
I130-D14-1407T-Z-SCP-□	7.06	14.12	1.44	7.88	22.19	20.44	13.07	10.31
I130-D14-1412T-Z-SCP-□	7.06	14.12	1.44	12.69	22.19	30.06	13.07	10.31
I130-D18-1807T-Z-SCP-□	9.06	18.12	1.81	7.88	25.50	20.44	15.94	13.09
I130-D18-1812T-Z-SCP-□	9.06	18.12	1.81	12.69	25.50	30.06	15.94	13.09

Your beam size must be added to complete model number. See previous pages.

* Window width each side of frame plate.

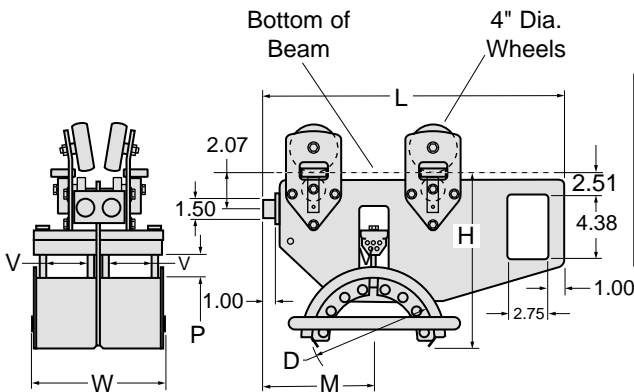

Tow Clamp *Optional...Replaces Tow Trolley (one required)*

Model Number w/ Std Hardware	Saddle Radius R	Saddle Dia. D	Window Height P	Window Width* V	Overall Length L	Overall Width W	Below Beam H	Saddle Locator M	Mtg. Locator J
I130-D10-3307C-Z	5.13	10.25	3.38	7.88	11.91	20.44	16.44	8.44	5.94
I130-D14-1407C-Z	7.06	14.12	1.44	7.88	14.50	20.44	16.62	9.94	7.44
I130-D14-1412C-Z	7.06	14.12	1.44	12.69	14.50	30.06	16.62	9.94	7.44
I130-D18-1807C-Z	9.06	18.12	1.81	7.88	17.84	20.44	19.50	12.69	10.19
I130-D18-1812C-Z	9.06	18.12	1.81	12.69	17.84	30.06	19.50	12.69	10.19

Fits all beam sizes. * Window width each side of frame plate.

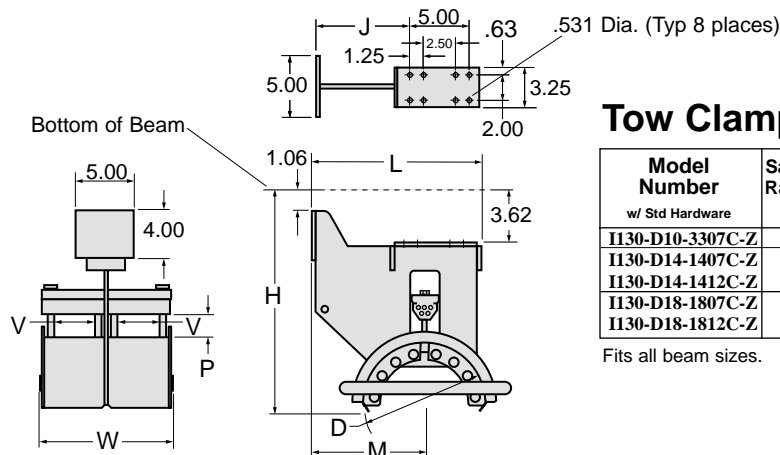

New State-of-the-Art Design

Heavy Duty Series I-152 and I-162

- All the **FEATURES** required for years of high speed service, even under the most rugged conditions.
- All the **OPTIONS** needed to precisely fit your specific application.

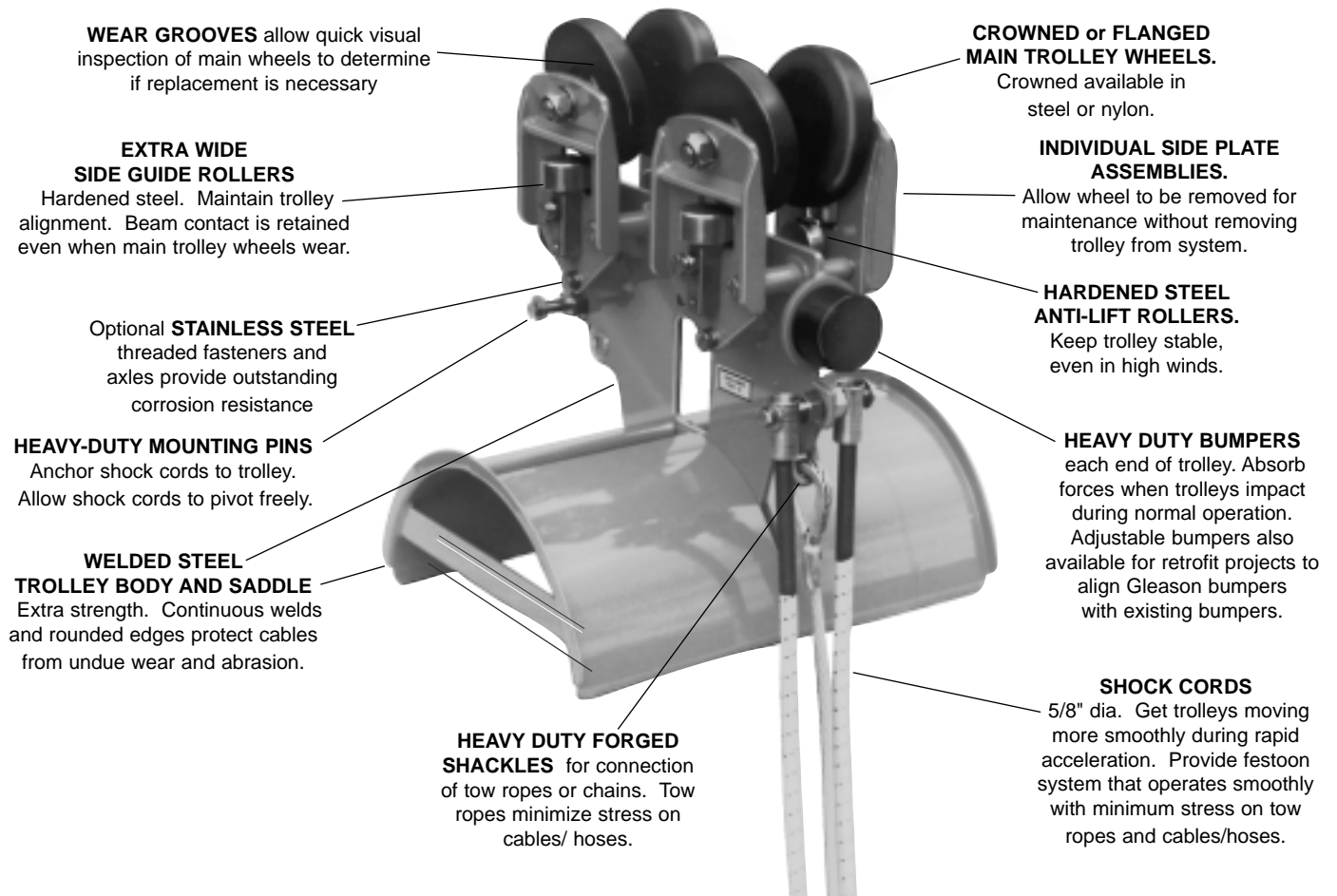

Choice of Cable Clamps or Clips

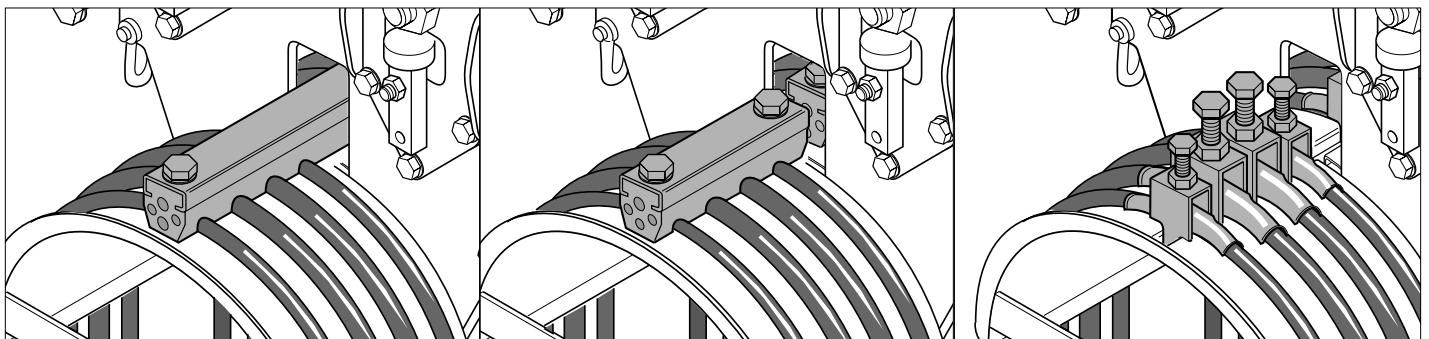

SINGLE CLAMP (left) or DUAL CLAMPS (center)
Single clamp standard on 11.5" & 15" wide saddles.
Dual clamps standard on 20"-30" wide saddles.

INDIVIDUAL CLIPS FOR EACH CABLE/ HOSE
Available as option on all saddle widths.