

Accessories



NO NEED TO SEARCH FOR THE CORRECT ACCESSORY MODEL!

When the Gleason festoon computer program elects a system, you simply indicate which accessories you desire and the correct model number will be selected for you and identified on the OUTPUT page.

These pages provide support data.

**ALL DIMENSIONS IN INCHES
UNLESS OTHERWISE INDICATED.**

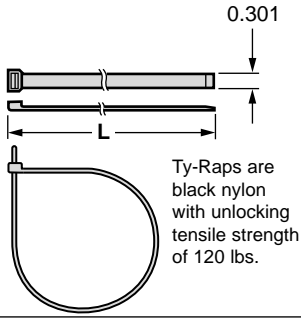

Ty-Raps are black nylon with unlocking tensile strength of 120 lbs.

Ty-Raps

MODEL NUMBER	BUNDLE RANGE	LENGTH L
TY - 08	0.19 - 2.00	8.00
TY - 13	0.19 - 3.50	13.88
TY - 30	1.50 - 9.00	30.00

Cable Clamps

FLAT CAMP DESIGN
SERIES C40-F, C50-F, C60-F

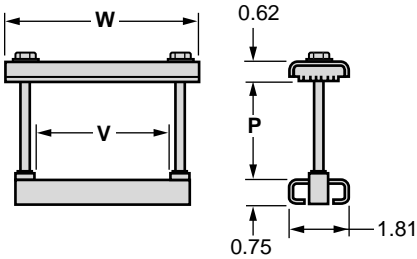

Clamping pads are neoprene.
Hardware is Zinc-plated steel.
Finish is orange polyester powder.

MODEL NUMBER	WINDOW V	WIDTH W
CL-F01-□-Z	1.88	3.75
CL-F02-□-Z	2.62	4.50
CL-F05-□-Z	5.00	6.88
CL-F06-□-Z	6.56	8.44
CL-F08-□-Z	8.56	10.44

May be supplied with stainless steel hardware.
Substitute "S" for "Z" in model numbers above.

PKG HGT CODE □	PKG HGT RANGE P
1	0.00 - 1.27
2	1.28 - 1.77
3	1.78 - 2.27
4	2.28 - 2.77
5	2.78 - 3.27
6	3.28 - 3.77
7	3.78 - 4.27
8	4.28 - 4.77

Code is substituted for □
to complete model number.

MIXED CAMP DESIGN
SERIES C40-F, C50-F, C60-F

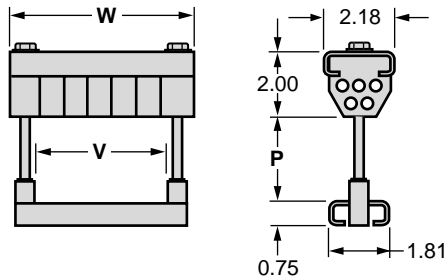

MODEL NUMBER	WINDOW V	WIDTH W
CL-M01-□-Z	1.88	3.75
CL-M02-□-Z	2.62	4.50
CL-M05-□-Z	5.00	6.88
CL-M06-□-Z	6.56	8.44
CL-M08-□-Z	8.56	10.44

May be supplied with stainless steel hardware.
Substitute "S" for "Z" in model numbers above.

PKG HGT CODE □	PKG HGT RANGE P
1	0.00 - 0.89
2	0.90 - 1.39
3	1.40 - 1.89
4	1.90 - 2.39
5	2.40 - 2.89

Track Hardware

Series C40, C50, C60

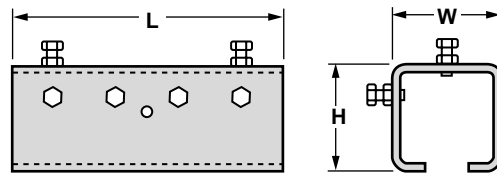
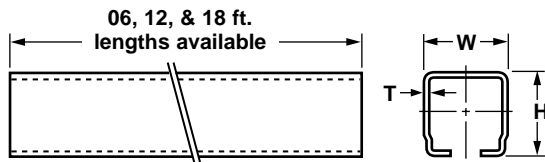

Rail Track Sections

MODEL NUMBER	WIDTH W	HEIGHT H	THICKNESS T
C40 - TR - □	1.260	1.180	0.079
C50 - TR - □	1.575	1.575	0.109
C60 - TR - □	1.968	1.968	0.123

Substitute length (06, 12, 18) for □
to complete model number.

Rail Coupler Assemblies

MODEL NUMBER	LENGTH L	WIDTH W	HEIGHT H
C40 - CP - Z	4.00	1.59	1.47
C50 - CP - Z	5.00	2.00	2.00
C60 - CP - Z	6.25	2.39	2.39

May be supplied with stainless steel hardware.
Substitute "S" for "Z" in model numbers above.

Series C50, C60 Tow Chain

MODEL NUMBER	HARDWARE OPTION
TC - □□.□ - Z	Zinc Plated Steel
TC - □□.□ - S	Stainless Steel

Tow Chains are straight-link No. 2/0 machine chain with zinc plate finish. Standard hardware is zinc plated steel. Load limit is 350 lbs.

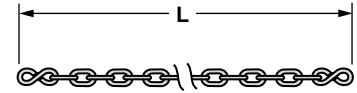

Substitute desired length in FEET for "□□.□" to complete Model Number. Round up in half-foot increments.

Junction Box WALL AND RAIL MOUNTED

MODEL NUMBER	RATING
JB - 03 - □ - W	NEMA 3
JB - 04 - □ - W	NEMA 4
JB - 4X - □ - W	NEMA 4X
JB - 12 - □ - W	NEMA 12
JB - 13 - □ - W	NEMA 13

CODE □	HEIGHT D	WIDTH W	DEPTH G
10	10.00	8.00	4.00
12	12.00	10.00	5.00
14	14.00	12.00	6.00
16	16.00	14.00	6.00

Substitute code above for "□" to complete Model Number.

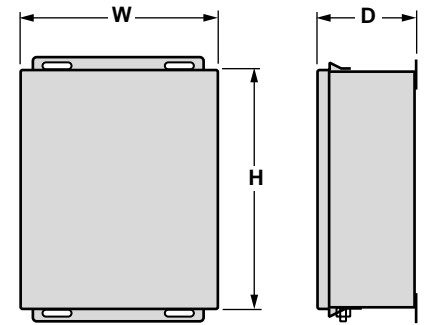

Substitute "R" for "W" in model number above for Rail Mounted junction box.

Terminal Blocks

MODEL NUMBER	S	MAX RATED AMPERES	FOR AWG SIZES
TB - 050	0.38	50	#24 thru #10
TB - 090	0.56	90	#8 thru #6
TB - 155	0.75	155	#4 thru #2
TB - 270	1.19	270	#1 thru #3/0

Ampere ratings above are general guidelines. Consult NEC for specific data.

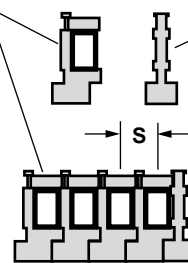

End Sections

MODEL NUMBER
TE - 050
TE - 090
TE - 155
TE - 270

Terminal Track Assembly

MODEL NUMBER	STYLE
TT - □ - S	Single
TT - □ - D	Double

Tracks mount in junction boxes and hold terminal blocks.

CODE □	HEIGHT D	WIDTH W
10	9.44	7.00
12	11.44	9.00
14	13.44	11.00
16	15.44	13.00

Substitute code above for "□" to complete Model Number.

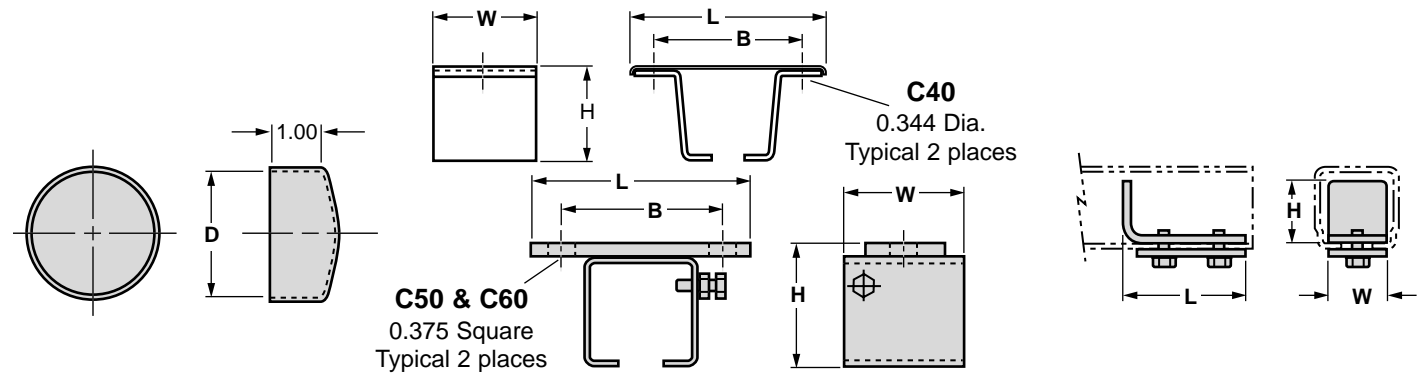
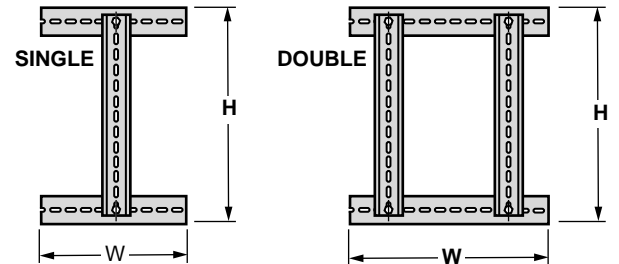

Vinyl End Caps

MODEL NUMBER	DIAMETER D
C40 - EC	1.50
C50 - EC	1.88
C60 - EC	2.38

Rail Hanger Assemblies

MODEL NUMBER	LENGTH L	WIDTH W	HEIGHT H	BOLTS B
C40-HB-Z	3.25	1.62	1.38	2.38
C50-HB-Z	4.12	2.00	2.25	3.12
C60-HB-Z	5.00	3.12	2.70	4.00

May be supplied with stainless steel hardware. Substitute "S" for "Z" in model numbers above.

Rail Endstop Assemblies

MODEL NUMBER	LENGTH L	WIDTH W	HEIGHT H
C40-ES-Z	2.00	0.88	0.88
C50-ES-Z	2.25	1.18	1.18
C60-ES-Z	4.00	1.75	2.25

May be supplied with stainless steel hardware. Substitute "S" for "Z" in model numbers above.