

GLEASON TRACK • MASTER™

SERIES C50-C

For ROUND Cable or Hose

- SINGLE-, DOUBLE-, OR TRIPLE-TIER CLIP DESIGN
- 1.25" DIA. PRECISION BALL BEARING STEEL WHEELS STANDARD

- MAX CABLE/HOSE O.D. = 2.38"
- MAX TROLLEY LOAD = 80 lbs.
- TRAVEL SPEEDS UP TO 350 fpm
- ACCELERATION—Consult us if over 2.0 ft/sec²
- MAX TRAVEL = 250 ft.—Consult us if greater

Standard Trolley Design

- 1.25" Dia. precision ball bearing wheels
- Bearings are pre-lubricated for life
- Tow trolley included as standard
- Hardware is zinc plated
- Orange baked polyester powder finish
- Includes heavy duty bumpers
- Cable/hose clips are adjustable †

GALVANIZED C-RAIL

SINGLE TIER CABLE CLIP
DOUBLE AND TRIPLE-TIER CLIP AVAILABLE

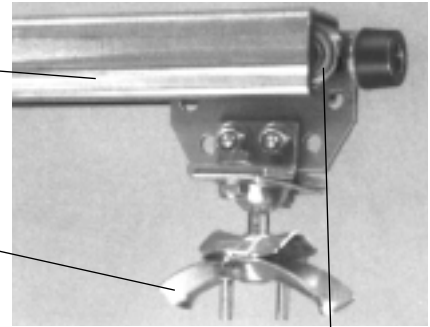

S

STEEL WHEELS
Bronze available

Model Number Explained

For STANDARD DESIGN, specific model numbers are on the following page.

TYPE	CLAMP STYLE	NO. OF TIERS (CLIPS)	CLIP O.D. CODE †	ITEM	Standard Hardware HARDWARE MATERIAL	Standard Wheels** WHEEL MATERIAL
#C50	C	1	1	I -	Z -	S
Chosen by computer					Hardware Option	Wheel Option
					S STAINLESS	B BRONZE

† 1 = 0.31"-0.59"; 2 = 0.60"-0.94"; 3 = 0.95"-1.25"; 4 = 1.26"-1.69"; 5 = 1.70"-2.38"
* Example above is for INTERMEDIATE TROLLEY (I) Use same option changes (at right) for other components as required.

**Not applicable to end clamps

Option Design Features

CODE	OPTION
B	BRONZE ANTI-SPARK WHEELS w/ BRONZE BEARINGS (De-rate maximum trolley load by 50% for bronze wheels)
S	STAINLESS STEEL HARDWARE
<input type="checkbox"/>	OTHER FINISHES AVAILABLE – PLEASE CONTACT US
<input type="checkbox"/>	FACTORY PRE-ASSEMBLY ON SHIPPING FRAME



STANDARD STEEL WHEELS

Bronze Anti-Spark Wheels
Optional

Track Hardware

See detail pages at back of catalog

- RAIL TRACK SECTIONS
- RAIL COUPLER ASSEMBLIES
- VINYL END CAPS
- RAIL HANGER ASSEMBLIES
- RAIL ENDSTOP ASSEMBLIES

Accessories

See detail pages at back of catalog

- TOW CHAINS
- HOSE - GENERAL PURPOSE or HYDRAULIC
- JUNCTION BOX(ES)
- CABLE - ROUND OR FLAT
- TERMINAL BLOCKS
- TY-WRAPS
- CABLE GLANDS FOR SINGLE CABLES OR GROUPS

Series C50-c Components & Dimensions

SINGLE, DOUBLE OR TRIPLE TIER DESIGN for ROUND CABLE OR HOSE

All dimensions in inches unless otherwise specified.

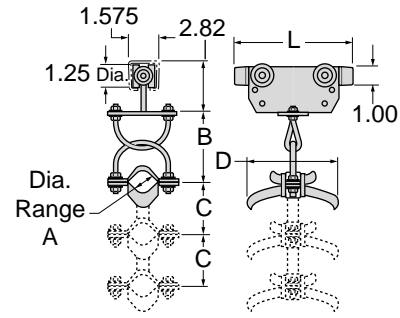
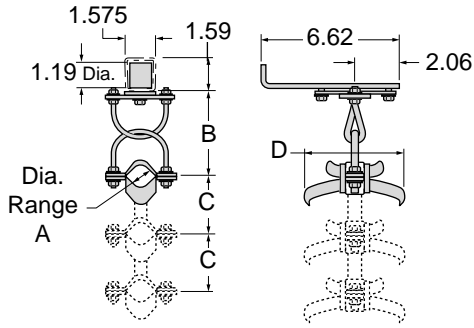

End Clip *One Required*

Model Number w/ Standard Hardware	No. Tiers	Cable/Hose O.D. Range A	B	Cable Centers C	Clip Length D
C50-C11E-Z	1	0.31-0.59	1.12	-	2.75
C50-C12E-Z	1	0.60-0.94	1.25	-	3.86
C50-C13E-Z	1	0.95-1.25	3.99	-	5.59
C50-C14E-Z	1	1.26-1.69	4.25	-	6.88
C50-C15E-Z	1	1.70-2.38	4.88	-	9.38
C50-C21E-Z	2	0.31-0.59	1.12	1.31	2.75
C50-C22E-Z	2	0.60-0.94	1.25	1.88	3.86
C50-C23E-Z	2	0.95-1.25	3.99	3.06	5.59
C50-C24E-Z	2	1.26-1.69	4.25	3.63	6.88
C50-C25E-Z	2	1.70-2.38	4.88	4.43	9.38
C50-C31E-Z	3	0.31-0.59	1.12	1.31	2.75
C50-C32E-Z	3	0.60-0.94	1.25	1.88	3.86
C50-C33E-Z	3	0.95-1.25	3.99	3.06	5.59
C50-C34E-Z	3	1.26-1.69	4.25	3.63	6.88
C50-C35E-Z	3	1.70-2.38	4.88	4.43	9.38

Intermediate Trolley *Quantity as Required*

Model Number Std Hardware & Wheels	No. Tiers	Cable/Hose O.D. Range A	B	Cable Centers C	Clip Length D	Trolley Length L
C50-C11I-Z-S	1	0.31-0.59	1.12	-	2.75	4.94
C50-C12I-Z-S	1	0.60-0.94	1.25	-	3.86	6.31
C50-C13I-Z-S	1	0.95-1.25	3.99	-	5.59	6.31
C50-C14I-Z-S	1	1.26-1.69	4.25	-	6.88	7.88
C50-C15I-Z-S	1	1.70-2.38	4.88	-	9.38	7.88
C50-C21I-Z-S	2	0.31-0.59	1.12	1.31	2.75	4.94
C50-C22I-Z-S	2	0.60-0.94	1.25	1.88	3.86	6.31
C50-C23I-Z-S	2	0.95-1.25	3.99	3.06	5.59	6.31
C50-C24I-Z-S	2	1.26-1.69	4.25	3.63	6.88	7.88
C50-C25I-Z-S	2	1.70-2.38	4.88	4.43	9.38	7.88
C50-C31I-Z-S	3	0.31-0.59	1.12	1.31	2.75	4.94
C50-C32I-Z-S	3	0.60-0.94	1.25	1.88	3.86	6.31
C50-C33I-Z-S	3	0.95-1.25	3.99	3.06	5.59	6.31
C50-C34I-Z-S	3	1.26-1.69	4.25	3.63	6.88	7.88
C50-C35I-Z-S	3	1.70-2.38	4.88	4.43	9.38	7.88

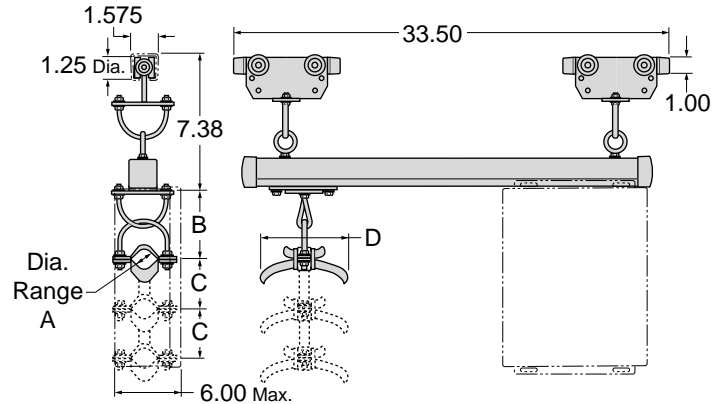
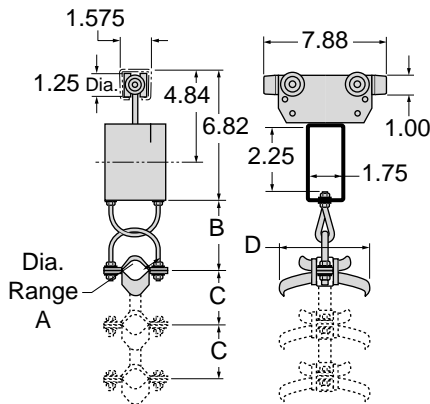

Tow Trolley *Standard...One Required*

Model Number Std Hardware & Wheels	No. Tiers	Cable/Hose O.D. Range A	B	Cable Centers C	Clip Length D
C50-C11T-Z	1	0.31-0.59	1.12	-	2.75
C50-C12T-Z	1	0.60-0.94	1.25	-	3.86
C50-C13T-Z	1	0.95-1.25	3.99	-	5.59
C50-C14T-Z	1	1.26-1.69	4.25	-	6.88
C50-C15T-Z	1	1.70-2.38	4.88	-	9.38
C50-C21T-Z	2	0.31-0.59	1.12	1.31	2.75
C50-C22T-Z	2	0.60-0.94	1.25	1.88	3.86
C50-C23T-Z	2	0.95-1.25	3.99	3.06	5.59
C50-C24T-Z	2	1.26-1.69	4.25	3.63	6.88
C50-C25T-Z	2	1.70-2.38	4.88	4.43	9.38
C50-C31T-Z	3	0.31-0.59	1.12	1.31	2.75
C50-C32T-Z	3	0.60-0.94	1.25	1.88	3.86
C50-C33T-Z	3	0.95-1.25	3.99	3.06	5.59
C50-C34T-Z	3	1.26-1.69	4.25	3.63	6.88
C50-C35T-Z	3	1.70-2.38	4.88	4.43	9.38

Control Unit Trolley *Optional...Replaces Tow Trolley*

Model Number Std Hardware & Wheels	No. Tiers	Cable/Hose O.D. Range A	B	Cable Centers C	Clip Length D
C50-C11U-Z	1	0.31-0.59	1.12	-	2.75
C50-C12U-Z	1	0.60-0.94	1.25	-	3.86
C50-C13U-Z	1	0.95-1.25	3.99	-	5.59
C50-C14U-Z	1	1.26-1.69	4.25	-	6.88
C50-C15U-Z	1	1.70-2.38	4.88	-	9.38
C50-C21U-Z	2	0.31-0.59	1.12	1.31	2.75
C50-C22U-Z	2	0.60-0.64	1.25	1.88	3.86
C50-C23U-Z	2	0.95-1.25	3.99	3.06	5.59
C50-C24U-Z	2	1.26-1.69	4.25	3.63	6.88
C50-C25U-Z	2	1.70-2.38	4.88	4.43	9.38
C50-C31U-Z	3	0.31-0.59	1.12	1.31	2.75
C50-C32U-Z	3	0.60-0.94	1.25	1.88	3.86
C50-C33U-Z	3	0.95-1.25	3.99	3.06	5.59
C50-C34U-Z	3	1.26-1.69	4.25	3.63	6.88
C50-C35U-Z	3	1.70-2.38	4.88	4.43	9.38

Note: Rail Mounted Junction Boxes are available.
See "Accessories" section at back of catalog.