

GLEASON TRACK • MASTER™

SERIES C40-c

For ROUND Cable or Hose

- SINGLE-, DOUBLE-, OR TRIPLE-TIER CLIP DESIGN
- 0.87" DIA. PRECISION BALL BEARING STEEL WHEELS STANDARD

- MAX CABLE/HOSE O.D. = 1.25"
- MAX TROLLEY LOAD = 50 lbs.
- TRAVEL SPEEDS UP TO 350 fpm.
- ACCELERATION—Consult us if over 2.0 ft/sec²
- MAX TRAVEL = 100 ft.—Consult us if greater

Standard Trolley Design

- 0.87" Dia. precision ball bearing wheels
- Bearings are pre-lubricated for life
- Tow trolley included as standard
- Hardware is zinc plated
- Orange baked polyester powder finish
- Cable/hose clips are adjustable †

GALVANIZED C-RAIL
STAINLESS STEEL TRACK AVAILABLE

SINGLE TIER CABLE CLIP
DOUBLE AND TRIPLE-TIER CLIP AVAILABLE

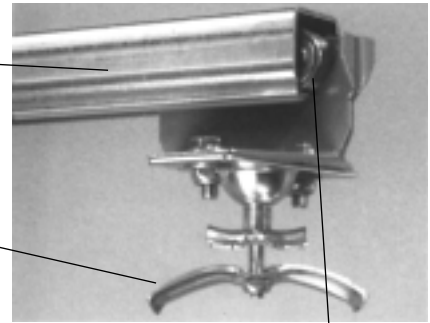

S

STEEL WHEELS

Model Number Explained

For STANDARD DESIGN, specific model numbers are on the following page.

Standard Intermediate Trolley *					Standard Hardware	Standard Wheels**
TYPE	CLAMP STYLE	NO. OF TIERS (CLIPS)	CLIP O.D. CODE †	ITEM	HARDWARE MATERIAL	WHEEL MATERIAL
#C40	C	1	1	I -	Z -	S
Chosen by computer				Options you select	ZINC PLATED	STEEL
					Hardware Option	S
					S	STAINLESS

† CLIP O.D. CODES: 1 = 0.31-0.59 IN.; 2 = 0.60-0.94 IN.; 3 = 0.95-1.25 IN.
* Example above is for INTERMEDIATE TROLLEY (I) Use same option changes (at right) for other components as required.

**Not applicable to end clamps

Option Design Features

CODE	OPTION
<input checked="" type="checkbox"/> S	STAINLESS STEEL HARDWARE
<input type="checkbox"/>	OTHER FINISHES AVAILABLE – PLEASE CONTACT US
<input type="checkbox"/>	FACTORY PRE-ASSEMBLY ON SHIPPING FRAME

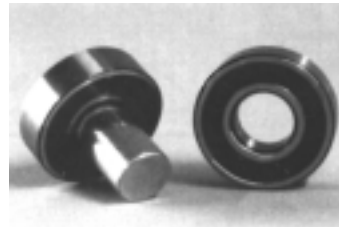

STANDARD STEEL WHEELS

Track Hardware

See detail pages at back of catalog

- RAIL TRACK SECTIONS
- RAIL COUPLER ASSEMBLIES
- VINYL END CAPS
- RAIL HANGER ASSEMBLIES
- RAIL ENDSTOP ASSEMBLIES

Accessories

See detail pages at back of catalog

- HOSE - GENERAL PURPOSE
- JUNCTION BOXES
- CABLE - ROUND OR FLAT
- TERMINAL BLOCKS
- TY-WRAPPS
- CABLE GLANDS FOR SINGLE CABLES OR GROUPS

Series C40-c Components & Dimensions

SINGLE, DOUBLE OR TRIPLE TIER DESIGN for ROUND CABLE OR HOSE

All dimensions in inches unless otherwise specified.

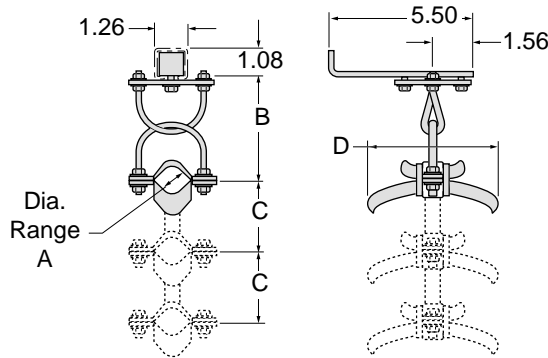

End Clip *One Required*

Model Number	No. Tiers	Cable/Hose O.D. Range A	B	Cable Centers C	Clip Length D
<i>w/ Standard Hardware</i>					
C40-C11E-Z	1	0.31-0.59	1.12	–	2.75
C40-C12E-Z	1	0.60-0.94	1.25	–	3.86
C40-C13E-Z	1	0.95-1.25	3.99	–	5.59
C40-C21E-Z	2	0.31-0.59	1.12	1.31	2.75
C40-C22E-Z	2	0.60-0.94	1.25	1.88	3.86
C40-C23E-Z	2	0.95-1.25	3.99	3.06	5.59
C40-C31E-Z	3	0.31-0.59	1.12	1.31	2.75
C40-C32E-Z	3	0.60-0.94	1.25	1.88	3.86
C40-C33E-Z	3	0.95-1.25	3.99	3.06	5.59

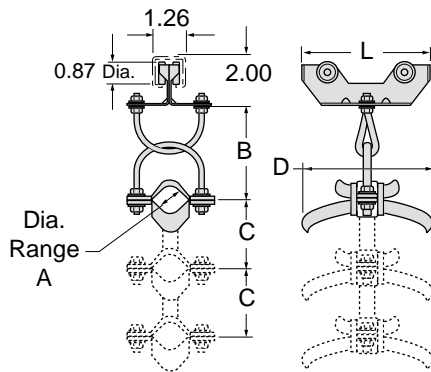

Intermediate Trolley *Quantity as Required*

Model Number	No. Tiers	Cable/Hose O.D. Range A	B	Cable Centers C	Clip Length D	Trolley Length L
<i>w/ Std Hardware & Wheels</i>						
C40-C11I-Z-S	1	0.31-0.59	1.12	–	2.75	3.12
C40-C12I-Z-S	1	0.60-0.94	1.25	–	3.86	3.12
C40-C13I-Z-S	1	0.95-1.25	3.99	–	5.59	3.12
C40-C21I-Z-S	2	0.31-0.59	1.12	1.31	2.75	3.12
C40-C22I-Z-S	2	0.60-0.94	1.25	1.88	3.86	3.12
C40-C23I-Z-S	2	0.95-1.25	3.99	3.06	5.59	3.12
C40-C31I-Z-S	3	0.31-0.59	1.12	1.31	2.75	3.12
C40-C32I-Z-S	3	0.60-0.94	1.25	1.88	3.86	3.12
C40-C33I-Z-S	3	0.95-1.25	3.99	3.06	5.59	3.12

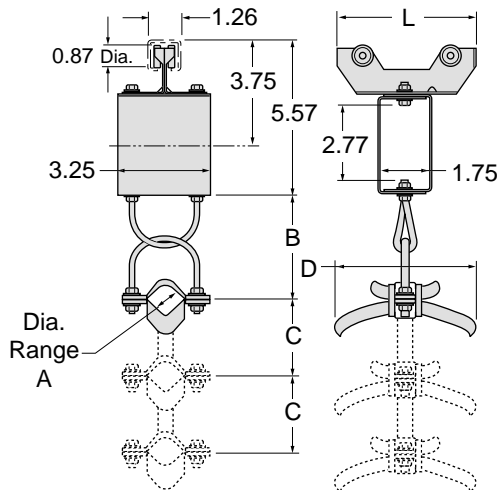

Tow Trolley *Standard...One Required*

Model Number	No. Tiers	Cable/Hose O.D. Range A	B	Cable Centers C	Clip Length D	Trolley Length L
<i>w/ Std Hardware & Wheels</i>						
C40-C11T-Z-S	1	0.31-0.59	1.12	–	2.75	5.00
C40-C12T-Z-S	1	0.60-0.94	1.25	–	3.86	5.00
C40-C13T-Z-S	1	0.95-1.25	3.99	–	5.59	5.00
C40-C21T-Z-S	2	0.31-0.59	1.12	1.31	2.75	5.00
C40-C22T-Z-S	2	0.60-0.94	1.25	1.88	3.86	5.00
C40-C23T-Z-S	2	0.95-1.25	3.99	3.06	5.59	5.00
C40-C31T-Z-S	3	0.31-0.59	1.12	1.31	2.75	5.00
C40-C32T-Z-S	3	0.60-0.94	1.25	1.88	3.86	5.00
C40-C33T-Z-S	3	0.95-1.25	3.99	3.06	5.59	5.00

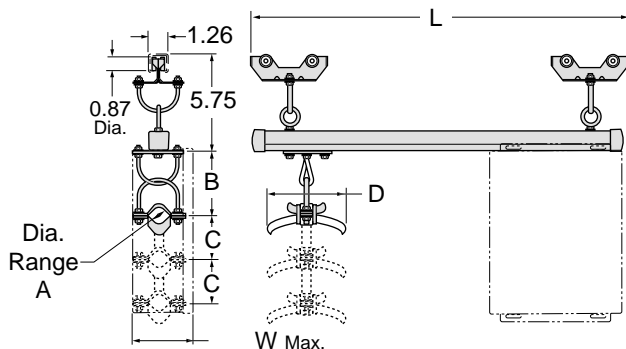

Control Unit Trolley *Optional...Replaces Tow Trolley*

Model Number	No. Tiers	Cable/Hose O.D. Range A	B	Cable Centers C	Clip Length D	Trolley Length L	Overall Width W
<i>w/ Std Hardware & Wheels</i>							
C40-C11U-Z-S	1	0.31-0.59	1.12	–	2.75	28.50	6.00
C40-C12U-Z-S	1	0.60-0.94	1.25	–	3.86	28.50	6.00
C40-C13U-Z-S	1	0.95-1.25	3.99	–	5.59	28.50	6.00
C40-C21U-Z-S	2	0.31-0.59	1.12	1.31	2.75	28.50	6.00
C40-C22U-Z-S	2	0.60-0.94	1.25	1.88	3.86	28.50	6.00
C40-C23U-Z-S	2	0.95-1.25	3.99	3.06	5.59	28.50	6.00
C40-C31U-Z-S	3	0.31-0.59	1.12	1.31	2.75	28.50	6.00
C40-C32U-Z-S	3	0.60-0.94	1.25	1.88	3.86	28.50	6.00
C40-C33U-Z-S	3	0.95-1.25	3.99	3.06	5.59	28.50	6.00

Note: Rail Mounted Junction Boxes are available.
See "Accessories" section at back of catalog.