

S21 DIRECT DRIVE

Dimensional Data & Optional Accessories

DIMENSIONS

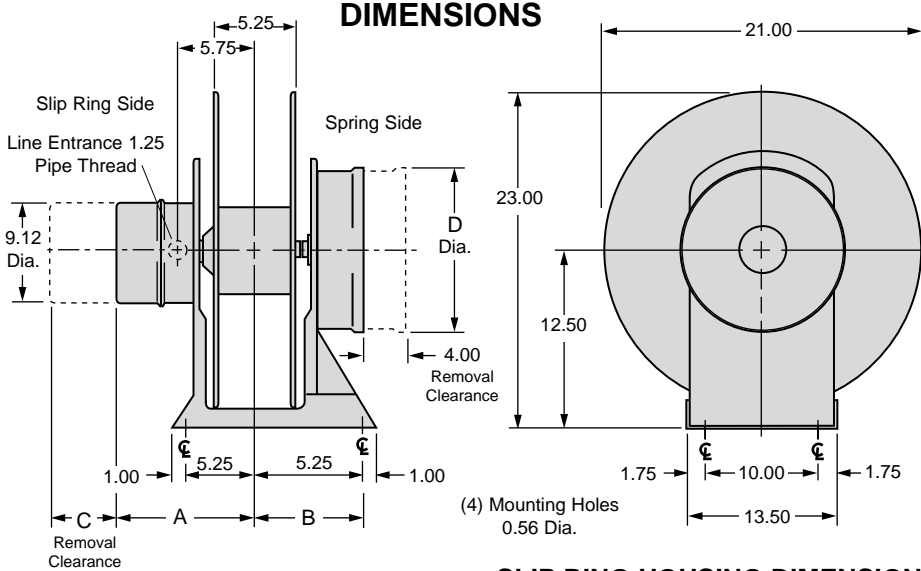

Cable payout, as pictured above, denotes reverse rotation.

SLIP RING HOUSING DIMENSIONS

Second Series of Digits in Model Number	23	63	37	103	143	203	303
	33	83	47	123	163	243	363
	43	27	212	312	412		
"A" Dimension-Inches	15.00	17.50	20.00	22.50	27.50	35.50	
"C" Dimension-Inches	8.50	11.00	13.50	16.00	21.00	29.00	

SPRING MOTOR DIMENSIONS CON'T

MODEL NUMBER	S21621	S21622	S21751	S21752	S21801	S21802	S211001
"B" Dimension in Inches	7.62	10.25	7.62	10.25	7.62	10.25	8.50
"D" Diameter in Inches	14.38	14.38	10.56	10.56	14.38	14.38	14.38
Approximate Net Weight of Reel with Spring Motor(s)	140	190	125	175	155	210	165

OPTIONAL ACCESSORIES

Vertical Roller Guide
Part No. 012082

If Hoop Guides are used, optional Roller Guides may be found on page 16.

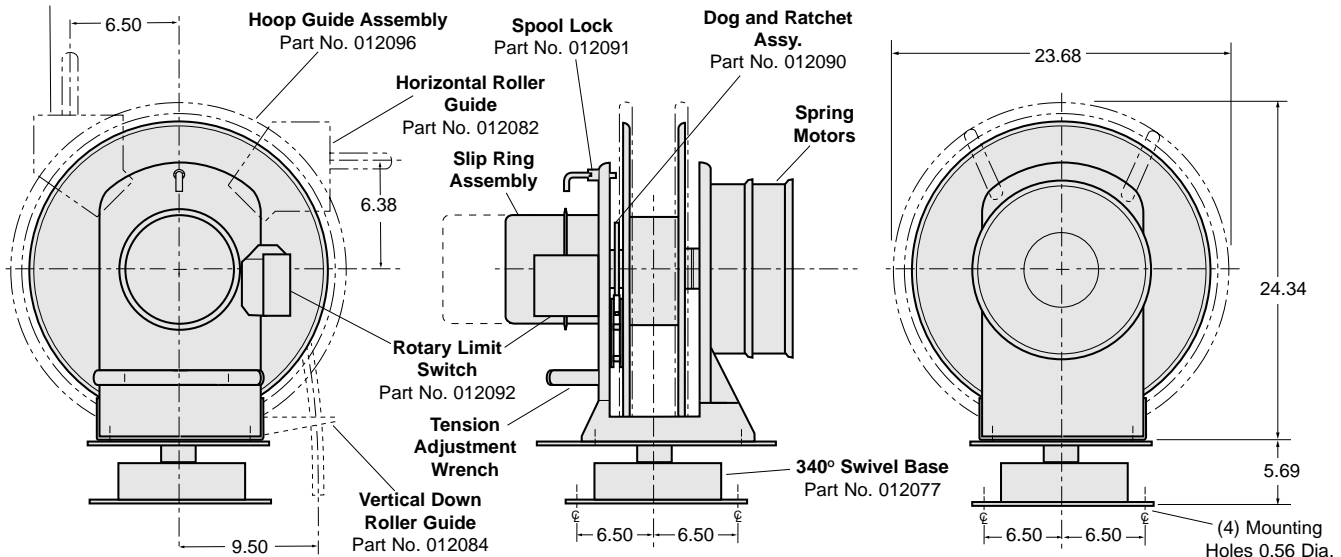

S21

GEARED DRIVE

Dimensional Data & Optional Accessories

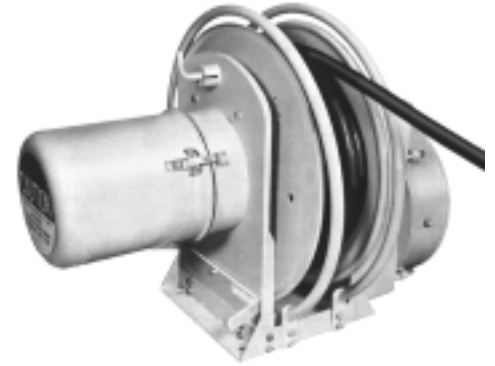
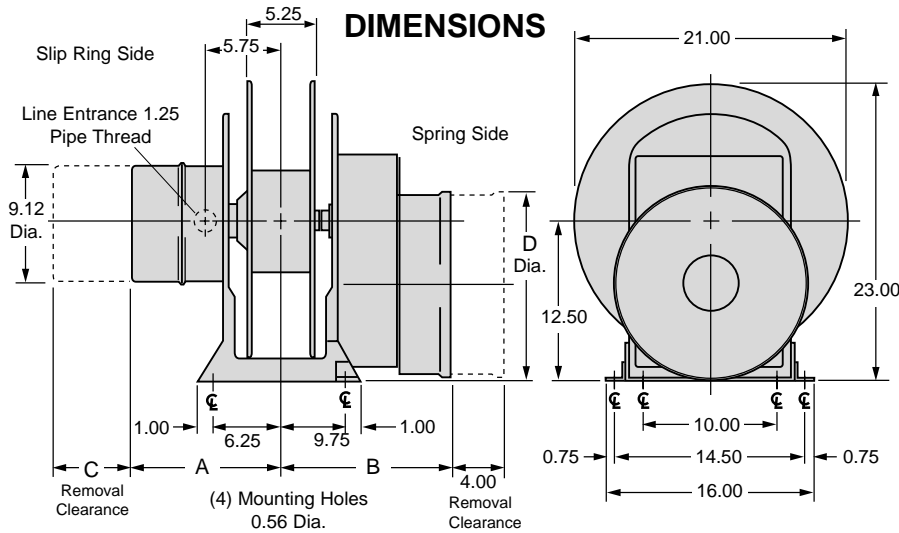

Cable payout, as pictured above, denotes standard rotation.

NOTE: Above illustration includes some of the optional accessories described below.

SLIP RING HOUSING DIMENSIONS

Second Series of Digits in Model Number	23	63
	33	83
	43	
"A" Dimension in Inches	15.00	17.50
"C" Dimension in Inches	8.50	11.00

SPRING MOTOR DIMENSIONS

MODEL NUMBER	S21801	S21802	S21803	S21804	S211001	S211002
"B" Dimension in Inches	12.62	15.25	17.88	20.50	13.50	16.88
"D" Diameter in Inches	14.38	14.38	14.38	14.38	14.38	14.38
Approximate Net Weight of Reel with Spring Motor(s)	180 lbs.	235 lbs.	290 lbs.	345 lbs.	190 lbs.	250 lbs.

OPTIONAL ACCESSORIES

Vertical Roller Guide
Part No. 012082

If Hoop Guides are used, optional Roller Guides may be found on page 16.

