

S18 DIRECT DRIVE

Dimensional Data & Optional Accessories

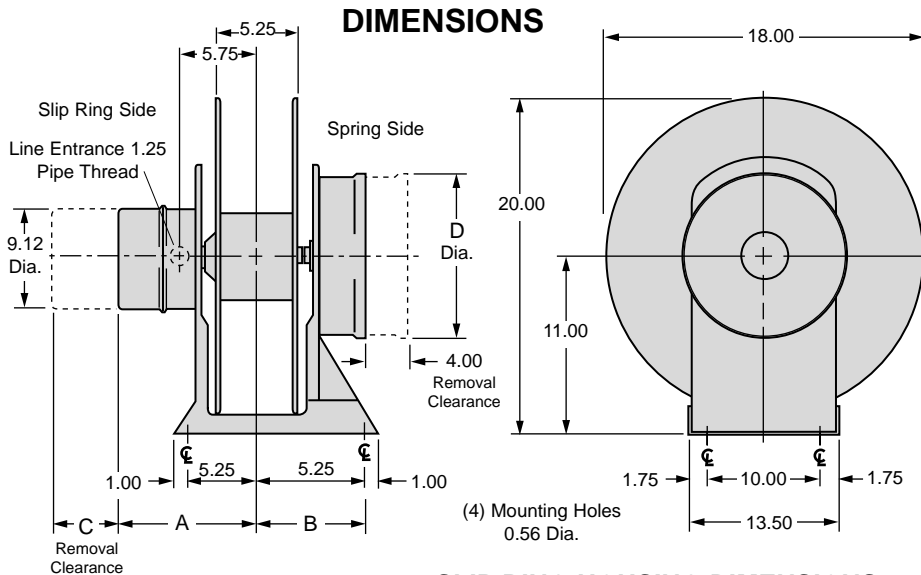

Cable payout, as pictured above, denotes reverse rotation.

SLIP RING HOUSING DIMENSIONS

Second Series of Digits in Model Number

23	63	37	103	143	203
33	83	47	123	163	243
43	27	212			

"A" Dimension-Inches

15.00	17.50	20.00	22.50	27.50
-------	-------	-------	-------	-------

"C" Dimension-Inches

8.50	11.00	13.50	16.00	21.00
------	-------	-------	-------	-------

SPRING MOTOR DIMENSIONS

MODEL NUMBER

S18621	S18622	S18751	S18801	S18802
--------	--------	--------	--------	--------

"B" Dimension in Inches

7.62	10.25	7.62	7.62	10.25
------	-------	------	------	-------

"D" Diameter in Inches

14.38	14.38	10.56	14.38	14.38
-------	-------	-------	-------	-------

Approximate Net Weight of Reel with Spring Motor(s)

130	180	115	145	200
-----	-----	-----	-----	-----

OPTIONAL ACCESSORIES

Vertical Roller Guide
Part No. 012082

If Hoop Guides are used, optional Roller Guides may be found on page 16.

