

# S16

## DIRECT DRIVE

## Dimensional Data & Optional Accessories

### DIMENSIONS

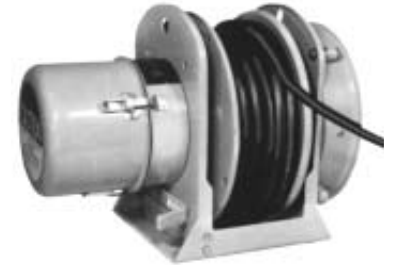
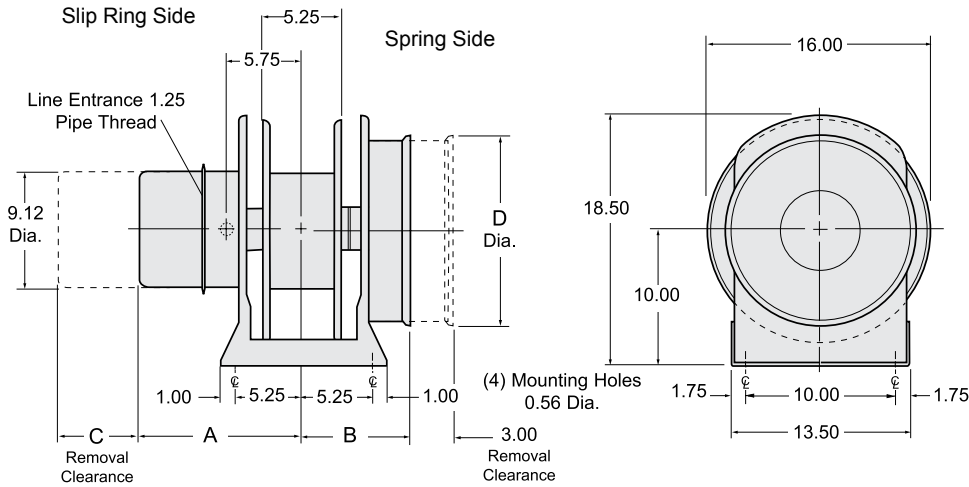

Cable payout, as pictured above, denotes standard rotation.

### SLIP RING HOUSING DIMENSIONS

Second Series of Digits in Model Number	23	63			
	33	83	130	143	203
	43	27	123	163	
		37			
		47			
"A" Dimensions in Inches	15.00	17.50	20.00	22.50	27.50
"C" Dimensions in Inches	8.50	11.00	13.50	16.00	21.00

### SPRING MOTOR DIMENSIONS

Model Number	S16351	S16601	S16621	S16622	S16751	S16801
"B" Dimensions in Inches	7.10	7.10	7.62	10.25	7.62	7.62
"D" Diameter in Inches	10.56	10.56	14.38	14.38	10.56	14.38
Approx. Net Weight of Reel with Spring Motor(s)	95 lbs.	100 lbs.	120 lbs.	170 lbs.	105 lbs.	135 lbs.

### OPTIONAL ACCESSORIES

