

# S14 DIRECT DRIVE

## Dimensional Data & Optional Accessories

### DIMENSIONS

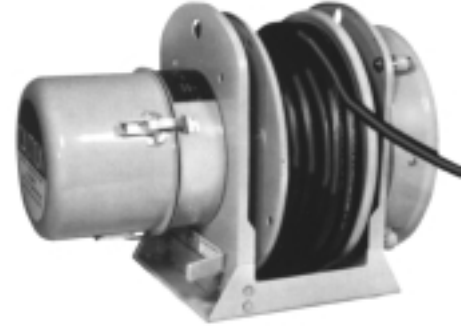
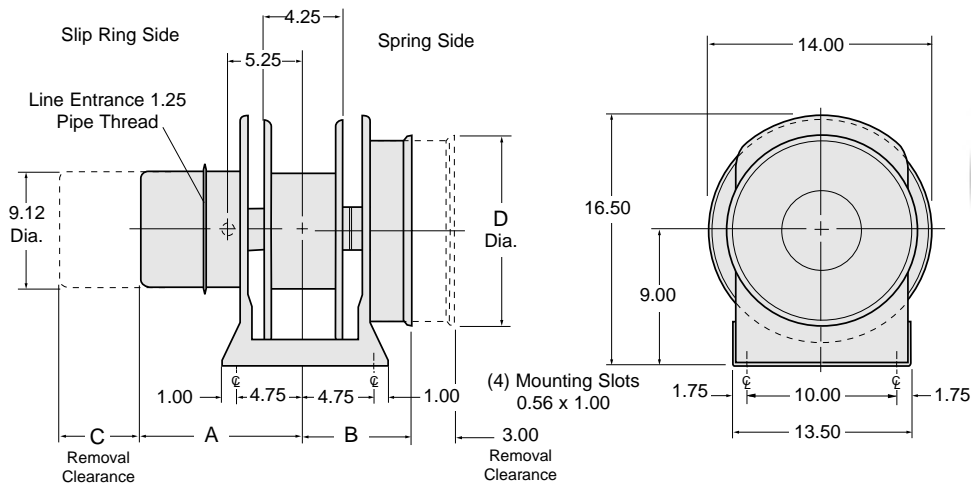

Cable payout, as pictured above, denotes standard rotation.

### SLIP RING HOUSING DIMENSIONS

Second Series of Digits in Model Number	23	63
	33	83
	43	27
"A" Dimension in Inches	14.50	17.00
"C" Dimension in Inches	8.50	11.00

### SPRING MOTOR DIMENSIONS

MODEL NUMBER	S14351	S14601	S14751
"B" Dimension in Inches	6.60	6.60	7.12
"D" Diameter in Inches	10.56	10.56	10.56
Approximate Net Weight of Reel with Spring Motor(s)	85 lbs.	90 lbs.	95 lbs.

### OPTIONAL ACCESSORIES

